

ENGINEERING AND GINNING

Second Stage Lint Cleaning System Particulate Emission Factors for Cotton Gins: Particle Size Distribution Characteristics

J. Clif Boykin, Michael D. Buser*, Derek P. Whitelock, and Gregory A. Holt

ABSTRACT

This report is part of a project to characterize cotton gin emissions from the standpoint of total particulate stack sampling and particle size analyses. In 2006 and again in 2013, the United States (U.S.) Environmental Protection Agency (EPA) published a more stringent National Ambient Air Quality Standard for particulate matter with nominal diameter less than or equal to 2.5 μm ($\text{PM}_{2.5}$). This created an urgent need to collect additional cotton gin emissions data to address current regulatory issues, because EPA AP-42 cotton gin $\text{PM}_{2.5}$ emission factors were limited. In addition, current EPA AP-42 included combined lint cleaner PM_{10} (particulate matter with nominal diameter less than or equal to 10 μm) and total particulate emission factors and not individual lint cleaner emission factors. The objective of this study was to characterize particulate emissions for 2nd stage lint cleaning systems from cotton gins across the cotton belt based on particle size distribution analysis of total particulate samples from EPA-approved stack sampling methods. Average measured $\text{PM}_{2.5}$, PM_6 , and PM_{10} emission factors based on the mass and particle size analyses of EPA Method 17 total particulate filter and wash samples from four gins (6 total test runs) were 0.00024 kg/227-kg bale (0.00052 lb/500-lb bale), 0.0026 kg/bale (0.0057 lb/bale), and 0.0048 kg/bale (0.010 lb/bale), respectively. The 2nd stage lint cleaning system particle size distributions

were characterized by an average mass median diameter of 29.8 μm (aerodynamic equivalent diameter). Based on system average emission factors, the ratio of $\text{PM}_{2.5}$ to total particulate was 1.04%, PM_6 to total particulate was 11.4%, and PM_{10} to total particulate was 20.9%.

In 2006 and again in 2013, the United States (U.S.) Environmental Protection Agency (EPA) published a more stringent standard for particulate matter (PM) with a particle diameter less than or equal to a nominal 2.5- μm ($\text{PM}_{2.5}$) aerodynamic equivalent diameter (AED) (CFR, 2013). The cotton industry's primary concern with this standard was the limited cotton gin $\text{PM}_{2.5}$ emissions data published in the literature and in EPA's AP-42, Compilation of Air Pollutant Emission Factors (EPA, 1996b). AP-42 was first circulated in 1972 and the last complete document revision was in 1995. Since 1995, only updates and supplements have been added. AP-42 contains air pollutant emission factors for more than 200 industrial sources of air pollution along with information on the processes conducted at these sources.

An emission factor is a relationship between a process and the amount of air pollution emitted by that process into the atmosphere (EPA, 1996b). Emission factors are usually defined as the weight of pollutant emitted per unit weight, volume, distance, or duration of the activity producing the pollutant (e.g., kilograms of particulate emitted per cotton bale ginned). These relationships have been established from source test data, modeling, material balance studies, and engineering estimates and are usually averages of all data that have been gathered for a particular process (EPA, 1996a).

EPA's AP-42 was developed to include emission factors for all criteria pollutants and additional pollutants beyond the scope of the National Ambient Air Quality Standards (NAAQS), including total PM, PM_{10} (PM with a particle diameter less than or equal to a nominal 10- μm AED), and $\text{PM}_{2.5}$. Current AP-42 cotton gin emission factors are located in section 9.7 (EPA, 1996b). Further, Appendix B.1

J.C. Boykin, USDA-ARS Cotton Ginning Research Unit, 111 Experiment Station Road, P.O. Box 256, Stoneville, MS 38776; M.D. Buser*, Biosystems and Agricultural Engineering, Oklahoma State University, 111 Agricultural Hall, Stillwater, OK 74078; D.P. Whitelock, USDA-ARS Southwestern Cotton Ginning Research Laboratory, 300 E College Dr., P.O. Box 578, Mesilla Park, NM 88047; and G.A. Holt, USDA-ARS Cotton Production and Processing Research Unit, 1604 E. FM 1294, Lubbock, TX 79403

*Corresponding author: buser@okstate.edu

of AP-42 contains particle size distribution (PSD) data and emission factors based on these PSDs (EPA, 1996c). The only PM_{2.5} emission factors in the current AP-42 were listed in Appendix B.1 and were based on PSDs. The 1996 AP-42 version only contained cotton ginning PSD data for the battery condenser and combined lint cleaning systems. The information for the battery condenser system equipped with cyclones was based on two tests and the PSD data was determined using a UW Mark 3 Impactor. The information for the combined lint cleaning system equipped with cyclones was based on four tests. The total particulate concentration data was determined using EPA Method 5 and the PSD data was determined by using a Coulter Counter to process the Method 5 samples (Hughes et al., 1982). Hughes et al. (1982) did not specifically state whether the PSD results were based on both the Method 5 wash and filter samples, wash only, or filter only. Table 1 provides examples of the types of data that were provided in EPA's AP-42 Appendix B.1.

Emission factors from EPA AP-42 developed prior to 2013 were assigned ratings to assess the quality of the data being referenced. The ratings ranged from A (excellent) to E (poor). The PSD data quality rating in the 1996 AP-42 for both the battery condenser and combined lint cleaning systems was E (EPA, 1996c).

Cotton ginners' associations across the U.S. cotton belt, including the National, Texas, Southern, Southeastern, and California associations, agreed that there was an urgent need to collect additional PSD data on PM being emitted from cotton ginning system exhausts. Working with cotton ginning associations across the country, state and federal regulatory agencies, Oklahoma State University, and USDA-Agricultural Research Service (ARS) researchers developed a proposal and sampling plan that was initiated in 2008 to address this need. Buser et al. (2012) provided the details of this sampling plan. This article is part of a series that details cotton gin emission factors developed from coupling total particulate stack sampling concentrations and particle size analyses. Each manuscript in the series

addresses a specific cotton ginning system. The systems covered in the series include: unloading, 1st stage seed-cotton cleaning, 2nd stage seed-cotton cleaning, 3rd stage seed-cotton cleaning, overflow, 1st stage lint cleaning, 2nd stage lint cleaning, combined lint cleaning, cyclone robber, 1st stage mote, 2nd stage mote, combined mote, mote cyclone robber, mote cleaner, mote trash, battery condenser, and master trash. This manuscript reports on the characterization of PM_{2.5} and PM₁₀ emissions from 2nd stage lint cleaning systems.

Cotton Ginning. Seed cotton is a perishable commodity that has no real value until the fiber and seed are separated (Wakelyn et al., 2005). Cotton must be processed or ginned at the cotton gin to separate the fiber and seed, producing 227-kg (500-lb) bales of marketable cotton fiber. Cotton ginning is considered an agricultural process and an extension of the harvest by several federal and state agencies (Wakelyn et al., 2005). Although the main function of the cotton gin is to remove the lint fiber from the seed, many other processes occur during ginning, such as cleaning, drying and packaging the lint. Pneumatic conveying systems are the primary method of material handling in a cotton gin. As material reaches a processing point, the conveying air is separated and emitted outside the gin through a pollution control device. The amount of PM emitted by a system varies with the process and the composition of the material being processed.

Cotton ginning is a seasonal industry with the ginning season lasting from 75 to 120 days, depending on the crop size and condition. Although the general trend for U.S. cotton production has remained constant at about 17 million bales per year during the last 20 years, production from year to year often varies greatly for various reasons, including climate and market pressure. The number of active gins in the U.S. has not remained constant, steadily declining from 1,018 in 2000 to 682 in 2011 (NASS, 2001, 2012). Consequently, the average cotton gin production capacity across the U.S. cotton belt has increased to an approximate average of 25 bales per hour (Valco et al., 2003, 2006, 2009, 2012).

Table 1. EPA AP-42 Appendix B.1 particle size distribution data for the battery condenser and combined lint cleaning systems equipped with cyclones on the system exhausts.

System	% < 2.5 μm	Emission Factor kg/bale	% < 6.0 μm	Emission Factor kg/bale	% < 10 μm	Emission Factor kg/bale
Lint cleaner	1	Not Reported	20	Not Reported	54	Not Reported
Battery condenser	8	0.007	33	0.028	62	0.053

Typical cotton gin processing systems include: unloading, dryers, seed-cotton cleaners, gin stands, overflow, lint cleaners, battery condenser, bale packaging, and trash handling (Fig. 1); however, the number and type of machines and processes can vary. Each of these systems serves a unique function with the ultimate goal of ginning the cotton to produce a marketable product. Raw seed cotton harvested from the field is compacted into large units called “modules” for delivery to the gin. The unloading system removes seed cotton either mechanically or pneumatically from the module feeding system and conveys the seed cotton to the cleaning systems. Seed-cotton cleaning systems assist in drying the seed cotton and removing foreign matter prior to ginning. Ginning systems also remove foreign matter and separate the cotton fiber from seed. Lint cleaning systems further clean the cotton lint after ginning. The battery condenser and packaging systems combine lint from the lint cleaning systems and compress the lint into dense bales for efficient transport. Gin systems produce by-products or trash, such as rocks, soil, sticks, hulls, leaf material, and short or tangled immature fiber (motes), as a result of processing the seed cotton or lint. These streams of by-products must be removed from the machinery and handled by trash collection systems. These trash systems typically further process the by-products (e.g., mote cleaners) and/or consolidate the trash from the gin systems into a hopper or pile for subsequent removal.

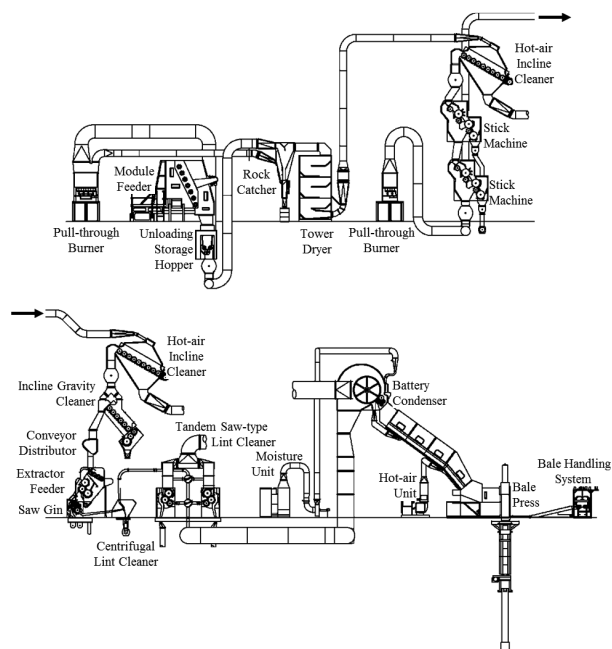

Figure 1. Typical modern cotton gin layout (Courtesy Lummus Corporation, Savannah, GA).

Cotton lint is cleaned in the lint cleaning systems (Fig. 2). In the typical 1st and 2nd stage lint cleaning system, cotton fiber or lint is pneumatically conveyed from the gin stands, through a centrifugal lint cleaner, to the 1st stage lint cleaners (cotton gins typically split the pre-cleaned seed-cotton among multiple, parallel gin stand/lint cleaning lines that are recombined at packaging) for further foreign matter removal. The lint is removed from the airstream with a rotating, screened separator drum and directed into the lint cleaner feed works. Lint cleaners remove fine trash, seed, and some lint. The material removed by lint cleaners is referred to as “motes”. Lint is directed from the lint cleaner to either a subsequent stage of lint cleaning or into the bale packaging system. A 2nd stage of lint cleaning is sometimes used and is essentially identical to the 1st stage. The airstream from the lint cleaner screened separator continues through a centrifugal fan to one or more particulate abatement cyclones. Some lint cleaning systems utilize a vane-axial fan, but these systems typically do not have cyclones and exhaust directly to ambient air. The pneumatic systems of the two lint cleaning stages might share a fan and abatement device or might operate independently, as is the case with 2nd stage lint cleaning systems. The material handled by the lint cleaner cyclones typically includes small trash and particulate, and lint fibers (Fig. 3).

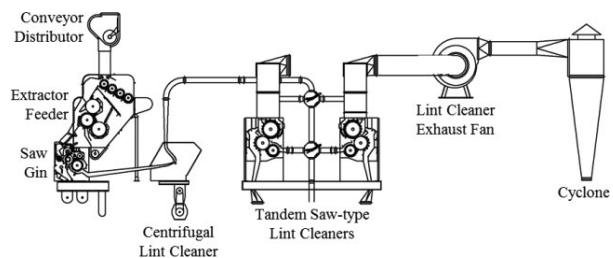

Figure 2. Typical cotton gin 2nd stage lint cleaning system layout (Courtesy Lummus Corporation, Savannah, GA).



Figure 3. Photograph of typical trash captured by the 2nd stage lint cleaning system cyclones.

Cyclones. Cyclones are the most common PM abatement devices used at cotton gins. Standard cyclone designs used at cotton ginning facilities are the 2D2D and 1D3D (Whitelock et al., 2009). The first D in the designation indicates the length of the cyclone barrel relative to the cyclone barrel diameter. The second D indicates the length of the cyclone cone relative to the cyclone barrel diameter. A standard 2D2D cyclone (Fig. 4) has an inlet height of $D/2$ and width of $D/4$ and design inlet velocity of 15.2 ± 2 m/s (3000 ± 400 fpm). The standard 1D3D cyclone (Fig. 4) has the same inlet dimensions as either the 2D2D or the original 1D3D inlet with height of D and width $D/8$. Also, it has a design inlet velocity of 16.3 ± 2 m/s (3200 ± 400 fpm).

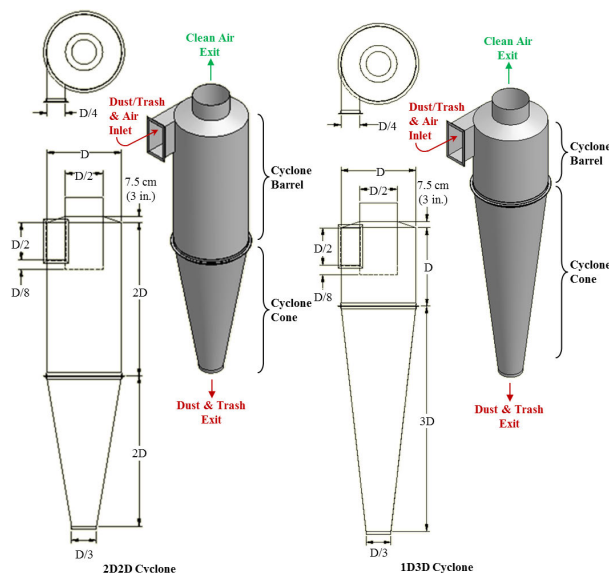

Figure 4. 2D2D and 1D3D cyclone schematics.

Cotton Gin Emission Factors. EPA emission factors for cotton gins are published in EPA's Compilation of Air Pollution Emission Factors, AP-42 (EPA, 1996b). There are no 1996 EPA AP-42 emission factors for 2nd stage lint cleaning systems. Second stage lint cleaning systems would be similar to lint cleaners listed in AP-42, but the AP-42 factor represents 1st and 2nd stage lint cleaning systems combined. The AP-42 average total particulate emission factor for combined lint cleaning with high-efficiency cyclones was 0.26 kg (0.58 lb) per 217-kg (480-lb) equivalent bale with a range of 0.041 to 1.0 kg (0.09-2.3 lb) per bale (EPA, 1996a, b). This average and range were based on six tests conducted in one geographical location. The EPA emission factor quality rating was D, which is the second lowest possible rating (EPA, 1996a). The

AP-42 average PM_{10} emission factor for the lint cleaners with high-efficiency cyclones was 0.11 kg (0.24 lb) per 217-kg (480-lb) equivalent bale with a range of 0.020 to 0.42 kg (0.043-0.93 lb) per bale (EPA, 1996a, b). This average and range were also based on six tests conducted in one geographical location, and the EPA emission factor quality rating was also D. Currently there are no $PM_{2.5}$ emission factor data listed in the EPA AP-42 for cotton gin 2nd stage lint cleaning systems.

Buser et al. (2012) discussed the plan of a large-scale project focused on developing cotton gin PM emission factors. Part of this project was focused on developing PM emission factors based on EPA-approved methodologies. Three studies focused on 2nd stage lint cleaning systems evolved out of the Buser et al. (2012) project plan. Buser et al. (2015) reported on one study that used EPA Method 17 (CFR, 1978) to measure total particulate emission factors for the 2nd stage lint cleaning systems. The system average total particulate emission factor was 0.023 kg (0.050 lb) per 227-kg (500-lb) equivalent bale with a range of 0.0092 to 0.035 kg (0.020-0.077 lb) per bale. Whitelock et al. (2014) reported on a second study that used EPA Method 201A (CFR, 2010) with only the PM_{10} sizing cyclone to measure 2nd stage lint cleaning system PM_{10} and total particulate emission factors. The system average PM_{10} and total particulate emission factors were 0.018 kg/227-kg bale (0.039 lb/500-lb bale) and 0.035 kg/bale (0.078 lb/bale), respectively. In the third study, reported by Boykin et al. (2013), EPA Method 201A with both the PM_{10} and $PM_{2.5}$ sizing cyclones was used to measure $PM_{2.5}$, PM_{10} , and total particulate emission factors. The average measured $PM_{2.5}$ emission factor was 0.0051 kg/227-kg bale (0.011 lb/500-lb bale). The PM_{10} and total particulate average emission factors were 0.022 kg/bale (0.048 lb/bale) and 0.033 kg/bale (0.074 lb/bale), respectively.

Particle size distribution analyses have been utilized in conjunction with total particulate sampling methods to calculate PM emissions concentration and factors for agricultural operations for more than forty years (Wesley et al., 1972). Some examples include: cattle feedlot operations (Sweeten et al., 1998), poultry production facilities (Lacey et al., 2003), nut harvesting operations (Faulkner et al., 2009), grain handling (Boac et al., 2009), swine finishing (Barber et al.,

1991), and cotton ginning (Hughes and Wakelyn, 1997). Buser and Whitelock (2007) reported cotton ginning emission concentrations based on EPA-approved PM_{2.5}, PM₁₀, and total particulate stack sampling methods and PSD analyses of the total particulate samples coupled with the total particulate concentrations to calculate PM_{2.5} and PM₁₀ concentrations. The mass median diameter (MMD) of the PM in the samples ranged from 6 to 8 μm . The study results indicated that the PSD and EPA sampler-based PM₁₀ concentrations were in good agreement, whereas the PM_{2.5} EPA sampler concentrations ranged from 5.8 to 13.3 times the PSD-based concentrations.

The primary objective of this study was to develop PSD characteristics for the PM emitted from cotton gin 2nd stage lint cleaning systems. The secondary objective was to develop PM_{2.5} and PM₁₀ emission factors for cotton gin 2nd stage lint cleaning systems equipped with cyclones on the system exhausts based on particle size distribution analysis of total particulate samples from EPA-approved stack sampling methods.

METHODS

Seven cotton gins were sampled across the cotton belt for the overall cotton gin sampling project described by Buser et al. (2012). Key factors for selecting specific cotton gins included: 1) facility location (geographically diverse), 2) production capacity (industry representative), 3) processing systems (typical for industry), and 4) particulate abatement technologies (properly designed and maintained 1D3D cyclones). Four of the seven gins were equipped with 2nd stage lint cleaning systems that were not combined with 1st stage lint cleaning systems. The 2nd stage lint cleaning systems sampled were typical for the industry. Gins A, C, and F had similar systems. For these systems, the cotton fiber or lint material was pneumatically conveyed from the 1st stage lint cleaning system to the 2nd stage lint cleaner. At the 2nd lint cleaner, the lint was separated from the conveying air by a screened separator and fed into the lint cleaner. The airstream then passed through a fan and exhausted through one or more cyclones. The 2nd stage lint cleaning systems at gin B were similar, except each 2nd stage lint cleaning system processed material/airstreams from two 1st stage lint cleaning systems. Buser et al. (2015) provided

system flow diagrams for the 2nd stage lint cleaning systems that were tested.

All 2nd stage lint cleaning systems sampled utilized 1D3D cyclones to control emissions (Fig. 4), but there were some cyclone design variations among the gins. All the gins, except gin F, split the system exhaust flow between two cyclones in a dual configuration (side by side as opposed to one behind another). The system airstream for gin F was exhausted through a single cyclone. Inlets on all the 2nd stage lint cleaning cyclones were 2D2D type. Expansion chambers were present on 2nd stage lint cleaning system cyclones at gins A and B. Gins C and F had standard cones. The cyclones tested at gins B, C, and F had cyclone robber systems pulling airflow from their trash exits. This configuration helps remove lint and trash from the cyclone that could otherwise circulate near the trash exit at the bottom of the cone for a period of time before dropping out. All of the cyclone variations outlined above, if properly designed and maintained, are recommended for controlling cotton gin emissions (Whitelock et al., 2009). Buser et al. (2015) provided detailed descriptions of the abatement cyclones that were tested.

Method 17 Stack Sampling. The samples utilized for the PSD analyses and gravimetric sample data used in developing the PSD characteristics and PSD-based emission factors were obtained from EPA Method 17 stack testing (CFR, 1978) that was conducted at the four gins with 2nd stage lint cleaning systems as part of the overall cotton gin sampling project described by Buser et al. (2012). The Method 17 sampling methods and the procedures for retrieving the filter and conducting acetone wash of the sampler nozzle are described in the EPA Method 17 documentation (CFR, 1978). Further details of the project specific sampling methods, procedures, and results of the EPA Method 17 stack testing were reported by Buser et al. (2015).

Laboratory Analysis. All laboratory analyses were conducted at the USDA-ARS Air Quality Lab (AQL) in Lubbock, TX. All filters were conditioned in an environmental chamber ($21 \pm 2^\circ\text{C}$ [$70 \pm 3.6^\circ\text{F}$]; $35 \pm 5\%$ RH) for 48 h prior to gravimetric analyses. Filters were weighed in the environmental chamber on a Mettler MX-5 microbalance (Mettler-Toledo Inc., Columbus, OH; 1 μg readability and 0.9 μg repeatability) after being passed through an anti-static device. The MX-5 microbalance was leveled

on a marble table and housed inside an acrylic box to minimize the effects of air currents and vibrations. To reduce recording errors, weights were digitally transferred from the microbalance directly to a spreadsheet. Technicians wore latex gloves and a particulate respirator mask to avoid contaminating the filter or sample. AQL procedures required that each sample be weighed three times. If the standard deviation of the weights for a given sample exceeded 10 μg , the sample was reweighed. Gravimetric procedures for the acetone wash tubs were the same as those used for filters.

In addition to gravimetric analyses, each sample was visually inspected for unusual characteristics, such as cotton lint content or extraneous material. Digital pictures were taken of all filters and washes for documentation purposes. After the laboratory analyses were completed all stack sampling, cotton gin production, and laboratory data were merged.

Particle Size Analysis. A Beckman Coulter LS230 laser diffraction system (Beckman Coulter Inc., Miami, FL) with software version 3.29 was used to perform the particle size analyses on the filter and wash samples. The instrument sizes particles with diameters ranging from 0.4 to 2000 μm . For this project, the LS230 fluid module was used with a 5% lithium chloride/methanol suspension fluid mixture. Approximately 10-L batches of the suspension fluid were prepared and stored in a self-contained, recirculating, filtration system equipped with 0.2 μm filters to keep the fluid well mixed and free of larger particles. Prior to each test run a background particle check was performed on the fluid to help minimize particulate contamination from non-sample sources. The process of analyzing the samples included the following steps:

1. pour approximately 40 mL of clean suspension fluid into a clean 100-mL beaker;
2. transfer a particulate sample to the 100-mL beaker with clean suspension fluid,
 - a. for 47-mm filter media, remove the filter from the Petri dish with tweezers and place the filter in the 100-mL beaker with the suspension fluid,
 - b. for the wash samples contained in a sample tub, use a small amount of the suspension fluid and a sterile foam swab to transfer the sample from the tub to the 100-mL beaker;
3. place the 100-mL beaker in an ultrasonic bath for 5 min to disperse the PM sample in the fluid;

4. using a sterile pipette, gradually introduce the PM and suspension fluid mixture into clean suspension fluid that is being monitored by the LS230 until an obscuration level of 10% is reached;
5. activate the LS230 system to measure the diffraction patterns and calculate the PSD;
6. repeat step 5 a total of three times and average the results; and
7. drain and flush/clean the LS230 system.

Optical models for calculating laser diffraction-based PSDs require input of a refractive index for the suspension fluid and real and imaginary refractive indices for the sample. A refractive index of 1.326 for methanol was used for the suspension fluid (Beckman Coulter, 2011). Hughs et al. (1997) showed that particulate from cyclone exhausts was about 34% ash or fine soil particulate with the balance made up of water and organic material (e.g., cellulose, lignin, protein). Real and imaginary refractive index values for common soil constituents—quartz, clay minerals, silica and feldspars—are 1.56 and 0.01, respectively (Buurman et al., 2001). These indices were used in the optical model used in calculating the PSD for the cyclone particulate samples. Wang-Li et al. (2013) and Buser (2004) provided additional details on the PSD methodology.

The LS230 PSD results are in the form of particle volume versus equivalent spherical diameter. The PSD results were converted to particle volume versus AED using the following equation:

$$d_a = d_p \left(\frac{\rho_p}{\kappa \rho_w} \right)^{1/2}$$

where ρ_w is the density of water with a value of 1 g/cm^3 , ρ_p is the particle density, and κ is the dynamic shape factor. The dynamic shape factor was determined to be 1.4 based on Hinds (1982) factors for quartz and sand dust. The particle density, assumed to be constant for the Method 17 filter and wash samples evaluated in this study, was determined in an earlier study to be 2.65 g/cm^3 (M. Buser, unpublished data, 2013). This earlier study used a helium displacement AccuPyc 1330 Pyconometer (Micromeritics, Norcross, GA) to determine the particle density of cotton gin waste that passed through a No. 200 sieve (particles that pass through a 74- μm sieve opening). The study was based on three random samples collected at 43 different cotton gins.

Results obtained from each average adjusted PSD included: MMD, mass fraction of PM with diameter less than or equal to 10 μm (PM_{10}), mass fraction of PM with diameter less than or equal to 6 μm (PM_6), and mass fraction of PM with diameter less than or equal to 2.5 μm ($\text{PM}_{2.5}$). This information was coupled with the corresponding Method 17 sample mass to calculate the PM_{10} , PM_6 , and $\text{PM}_{2.5}$ emission factors using the following equation:

$$EF_i = EF_{tot} \left(\left(\frac{M_F}{M_F + M_W} \right) w_{Fi} + \left(\frac{M_W}{M_F + M_W} \right) w_{Wi} \right)$$

where EF_i = emission factor for particle in the size range i ;

EF_{tot} = total particulate emission factor obtained from total particulate tests (Buser et al., 2015);

M_F = total mass of particulate on filter;

M_W = total mass of particulate in nozzle wash;

w_{Fi} = mass fraction of particles on the filter in the size range i ; and

w_{Wi} = mass fraction of particles in the nozzle wash in the size range i .

The 2nd stage lint cleaning systems sampled were typical for the industry. The system average ginning rate was 29.0 bales/h and the test average ginning rate at each gin ranged from 18.5 to 49.6 bales/h (based on 227-kg [500-lb] equivalent bales). The capacity of gins sampled was representative of the industry average, approximately 25 bales/h. The 1D3D cyclones were all operated with inlet velocities within design criteria, 16.3 ± 2 m/s (3200 ± 400 fpm), except the test runs at gins A and C were outside the design range due to limitations in available system adjustments. There are criteria specified in EPA Method 17 for test runs to be valid for total particulate measurements (CFR, 1978). Isokinetic sampling must fall within EPA-defined range of $100 \pm 10\%$. All tests met the isokinetic criteria. The stack gas temperatures ranged from 20 to 39°C (68-102°F) and moisture content ranged from 1.0 to 3.8%. The individual systems and cyclone design variations were discussed by Buser et al. (2015).

RESULTS

The PSD characteristics and mass of the PM captured on the filters are shown in Table 2. The mass of the PM captured on the filter accounted for

41 to 96% of the total PM (filter and wash) collected from the individual test runs. The mass of the gin C test run 1 sample was too low for PSD analyses. The system average MMD for particulate on the filters was 28.0 μm AED. Test averages ranged from 17.9 to 48.0 μm AED. The test and system averages are based on averaging PSDs and not averaging individual test results. The mass fraction of $\text{PM}_{2.5}$, PM_6 , and PM_{10} ranged from 0.83 to 1.58%, 6.0 to 16.7%, and 11.1 to 31.2%, respectively. Filter PM PSDs for the four gins and the system average are shown in Fig. 5. In general, the PSD characteristics for the PM captured on the filters for the four gins were consistent. The PSDs for gins A, B, and F show a shift to the right compared to gin C illustrating the effect of a larger MMD.

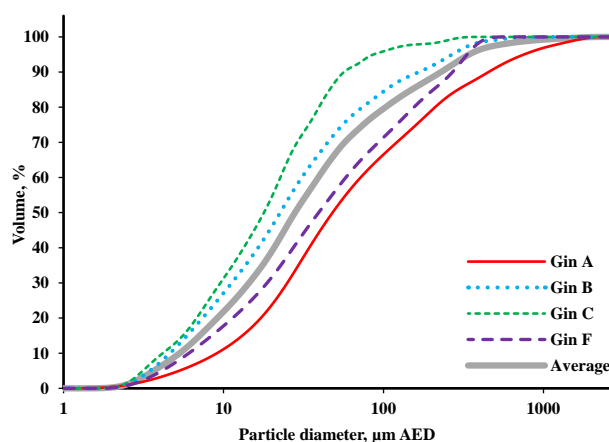

Figure 5. Gin average cumulative particle size distributions for the PM captured on a EPA-Method 17 filter from the 2nd stage lint cleaning systems.

The PSD characteristics and mass of the PM captured in the washes are shown in Table 3. The mass of the PM captured in the sampler nozzle and retrieved in the wash accounted for 4 to 59% of the total PM (filter and wash) collected from the individual test runs. The mass of the gin B test runs 1 and 2 and all test runs for gin C samples were too low for PSD analyses. The mass of the gin B test run 3 and test run 1 for gin F samples were marginal for PSD analyses. The system average MMD was 19.5 μm AED. Test average MMDs ranged from 10.9 to 28.2 μm AED. The mass fraction of $\text{PM}_{2.5}$, PM_6 , and PM_{10} ranged from 0.79 to 2.77%, 9.6 to 26.8%, and 18.2 to 46.5%, respectively. PSDs for the PM captured in the nozzle for the gins and the system average are shown in Fig. 6. The PSDs for gins B and F exhibit the characteristics of samples with marginal PM mass for PSD analysis with many peaks across the range of particle sizes.

Table 2. EPA Method 17 filter particle size distribution data for the 2nd stage lint cleaning system.

Gin	Test Run	Mass Median Diameter µm AED	PM _{2.5} %	PM ₆ %	PM ₁₀ %	Sample Total mg
A	1	43.7	1.06	6.6	12.2	8.58
	2	51.4	0.95	5.7	10.5	9.21
	3	49.7	0.93	5.7	10.7	9.86
	Test Average (n = 3) ^y	48.0	0.98	6.0	11.1	
B	1	23.1	1.60	15.2	26.1	1.75
	2	21.5	1.68	17.3	29.6	1.73
	3	23.2	0.54	13.4	25.6	1.15
	Test Average (n = 3) ^y	22.6	1.27	15.3	27.1	
C	1 ^z	–	–	–	–	0.49
	2	13.7	1.37	20.4	39.3	1.03
	3	22.7	1.79	13.0	23.2	6.56
	Test Average (n = 3) ^y	17.9	1.58	16.7	31.2	
F	1	36.4	0.95	10.6	19.2	13.33
	2	42.5	0.72	9.0	16.3	12.46
	3	36.6	1.13	10.4	18.8	12.01
	Test Average (n = 3) ^y	39.3	0.83	9.8	17.8	
System Average (n = 4) ^y		28.0	1.17	12.0	21.8	

^z Insufficient sample for particle size distribution^y Based on averaged particle size distributionsTable 3. EPA Method 17 nozzle wash particle size distribution data for the 2nd stage lint cleaning system.

Gin	Test Run	Mass Median Diameter µm AED	PM _{2.5} %	PM ₆ %	PM ₁₀ %	Sample Total mg
A	1	31.5	1.59	9.7	17.6	2.62
	2	24.1	1.05	10.0	20.4	2.51
	3	31.6	1.47	9.0	16.7	1.98
	Test Average (n = 3) ^x	28.2	1.37	9.6	18.2	
B	1 ^z	–	–	–	–	0.73
	2 ^z	–	–	–	–	0.64
	3	10.9	2.77	26.8	46.5	0.49
	Test Average (n=1)					
C	1 ^z	–	–	–	–	0.72
	2 ^z	–	–	–	–	0.55
	3 ^z	–	–	–	–	0.29
	Test Average (n=0)					
F	1	32.5	0.54	11.4	19.5	0.82
	2	21.7	1.04	15.9	28.8	1.29
	3 ^y	–	–	–	–	–
	Test Average (n = 2) ^x	26.3	0.79	13.7	24.2	
System Average (n = 3) ^x		19.5	1.64	16.7	29.6	

^z Insufficient sample for particle size distribution^y Sample omitted due to wash error^x Based on averaged particle size distributions

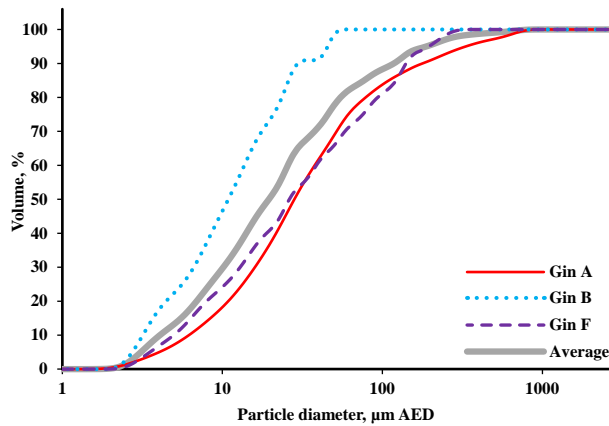

Figure 6. Gin average cumulative particle size distributions for the PM captured in the EPA-Method 17 sampler nozzle wash from the 2nd stage lint cleaning systems.

The combined PSD characteristics for the PM captured on the filter and PM captured in the wash are shown in Table 4. The 2nd stage lint cleaning system average combined filter and wash PSD MMD was 29.8 µm AED (17.9 to 42.5 µm test average range). There were no particles less than 1.0 µm in diameter. The combined filter and wash PM_{2.5}, PM₆, and PM₁₀ mass fractions ranged from 0.84 to 1.21%, 6.7 to 17.5%, and 12.6 to 31.8%, respectively. Combined PM PSDs for the gins and the system average are shown in Fig. 7. These combined PSDs are more consistent with the filter PSDs than the wash PSDs. This was expected because the majority of the PM mass was captured on the filter as compared to the nozzle wash.

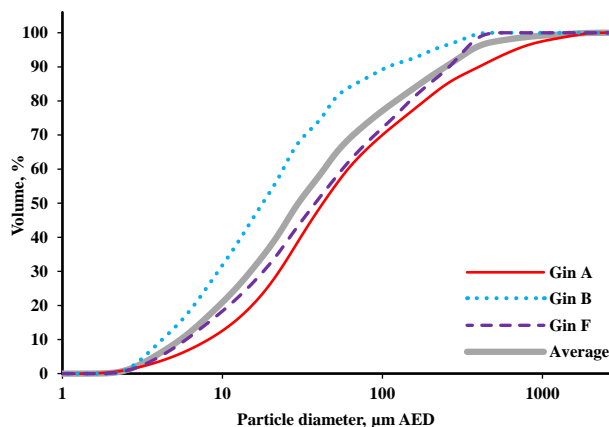

Figure 7. Gin average cumulative particle size distributions for the EPA-Method 17 combined filter and wash samples from the 2nd stage lint cleaning systems.

The PSD-based emission factors for the 2nd stage lint cleaning systems are shown in Table 5. The system average PM_{2.5} emission factor was 0.00024 kg/227-kg bale (0.00052 lb/500-lb bale). PM_{2.5} emission factors ranged from 0.000080 to 0.00038

kg (0.00018-0.00084 lb) per bale. The 2nd stage lint cleaning system average PM₆ emission factor was 0.0026 kg/bale (0.0057 lb/bale). The PM₆ emission factors ranged from 0.0011 to 0.0032 kg/bale (0.0025-0.0071 lb/bale). The 2nd stage lint cleaning system average PM₁₀ emission factor was 0.0048 kg/bale (0.010 lb/bale) and ranged from 0.0021 to 0.0059 kg (0.0046-0.013 lb) per bale. The ratios of PM_{2.5} to total particulate, PM₆ to total particulate, and PM₁₀ to total particulate, based on the system averages, were 1.04, 11.4, and 20.9%, respectively.

The PSD-based 2nd stage lint cleaning system PM_{2.5} emission factor was approximately 4.6% of the PM_{2.5} emission factor reported by Boykin et al. (2013) and measured using EPA Method 201A, 0.0051 kg (0.011 lb) per 227-kg (500-lb) bale. The PSD-based 2nd stage lint cleaning system PM₁₀ emission factor was 4.4% of the EPA AP-42 published value for the combined 1st and 2nd stage lint cleaning system with high efficiency cyclones, 0.11 kg (0.24 lb) per bale (EPA, 1996a). Also, the PSD-based system PM₁₀ emission factor was 27% of the Method 201A (PM₁₀ sizing cyclone only) PM₁₀ emission factor reported by Whitelock et al. (2014), 0.018 kg (0.039 lb) per bale. The PSD-based PM₁₀ emission factor was 22% of the Method 201A (PM₁₀ and PM_{2.5} sizing cyclones) PM₁₀ emission factor reported by Boykin et al. (2013), 0.022 kg (0.048 lb) per bale. The differences among the methods could be attributed to several sources. First, due to constraints in the EPA methods, the three studies utilizing Method 17 for total particulate sampling and PSD analyses, Method 201A for PM₁₀ sampling, and Method 201A for PM_{2.5} and PM₁₀ sampling could not be conducted simultaneously. Combined with the fact that emissions from cotton ginning can vary with the condition of incoming cotton, PM concentrations measured among the three studies could have varied. Second, for reasons described by Buser (2007a, b, c) and documented by Buser and Whitelock (2007), some larger particles could penetrate the Method 201A sampler PM₁₀ or PM_{2.5} sizing cyclones and collect on the filter. Finally, cotton fibers have a cross-sectional diameter much larger than 10 µm and are difficult to scrub out of air streams. These fibers could cycle in the sizing cyclones and pass through to deposit on the filters. This behavior was observed during some of the Method 201A testing where cotton fibers were found in Method 201A sampler washes and on filters (Fig. 8). Currently there are no EPA-approved guidelines to adjust Method 201A PM₁₀ or PM_{2.5} concentration measurements to account for these fibers.

Table 4. EPA Method 17 combined filter and wash particle size distribution data for the 2nd stage lint cleaning system.

Gin	Test Run	Mass Median Diameter µm AED	PM _{2.5} %	PM ₆ %	PM ₁₀ %
A	1	40.7	1.19	7.3	13.5
	2	41.4	0.97	6.6	12.6
	3	45.6	1.02	6.2	11.7
	Test Average (n = 3) ^x	42.5	1.06	6.7	12.6
B	1 ^z	–	–	–	–
	2 ^z	–	–	–	–
	3	17.9	1.21	17.5	31.8
Test Average (n=1)					
C	1 ^z	–	–	–	–
	2 ^z	–	–	–	–
	3 ^z	–	–	–	–
Test Average (n = 0)					
F	1	36.1	0.92	10.7	19.2
	2	40.2	0.75	9.7	17.4
	3 ^y	–	–	–	–
	Test Average (n = 2) ^x	38.1	0.84	10.2	18.3
System Average (n = 3) ^x		29.8	1.04	11.4	20.9

^z Insufficient sample for particle size distribution^y Sample omitted due to wash error^x Based on averaged particle size distributionsTable 5. EPA Method 17 total particulate and particle size distribution-based PM_{2.5}, PM₆, and PM₁₀ emission factor data for the 2nd stage lint cleaning system.

Gin	Test Run	Total ^w		PM _{2.5} ^y		PM ₆ ^y		PM ₁₀ ^y	
		kg/bale ^z	lb/bale ^z	kg/bale ^z	lb/bale ^z	kg/bale ^z	lb/bale ^z	kg/bale ^z	lb/bale ^z
A	1	0.032	0.071	0.00038	0.00084	0.0023	0.0051	0.0043	0.0095
	2	0.035	0.077	0.00034	0.00074	0.0023	0.0051	0.0044	0.0097
	3	0.037	0.082	0.00038	0.00084	0.0023	0.0051	0.0044	0.0096
B	1 ^y	0.011	0.024	–	–	–	–	–	–
	2 ^y	0.010	0.022	–	–	–	–	–	–
	3	0.0066	0.014	0.000080	0.00018	0.0011	0.0025	0.0021	0.0046
C	1 ^y	0.0062	0.014	–	–	–	–	–	–
	2 ^y	0.0090	0.020	–	–	–	–	–	–
	3 ^y	0.035	0.078	–	–	–	–	–	–
F	1	0.030	0.067	0.00028	0.00062	0.0032	0.0071	0.0059	0.013
	2	0.030	0.066	0.00023	0.00050	0.0029	0.0064	0.0053	0.012
	3 ^x	–	–	–	–	–	–	–	–
System Average		0.023	0.050	0.00024	0.00052	0.0026	0.0057	0.0048	0.010

^z 227-kg (500-lb) equivalent bales^y Insufficient sample for particle size distribution^x Sample omitted due to wash error^w Taken from Buser et al. (2015)^y Factors are the product of the corresponding PM percentage from Table 4 and the total particulate emission factor.

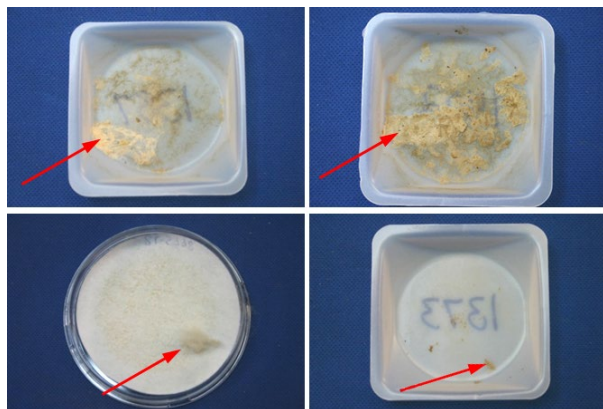

Figure 8. Example EPA Method 201A filter and sampler head acetone washes with lint (indicated by arrows) in the washes and on the filter. Clockwise from top left: $> 10 \mu\text{m}$ wash, 10 to $2.5 \mu\text{m}$ wash, $\leq 2.5 \mu\text{m}$ wash, and filter.

SUMMARY

Cotton gins across the U.S. cotton belt were sampled using EPA-approved methods to fill the data gap that exists for $\text{PM}_{2.5}$ cotton gin emissions data and to collect additional data to improve the EPA AP-42 total and PM_{10} emission factor quality ratings for cotton gins. Samples were further analyzed to characterize the PSD of the particulate measured. Four selected cotton gins had 2nd stage lint cleaning systems that used pneumatic conveyance and had exhaust airstreams that were not combined with another system. All tested systems were similar in design and typical of the ginning industry and were equipped with 1D3D cyclones for emissions control. In terms of capacity, the four gins were typical of the industry, averaging 29.0 bales/h during testing. The average PSD-based 2nd stage lint cleaning system $\text{PM}_{2.5}$, PM_6 , and PM_{10} emission factors from the four gins tested (6 total test runs) were 0.00024 kg/227-kg bale (0.00052 lb/500-lb bale), 0.0026 kg/bale (0.0057 lb/bale), and 0.0048 kg/bale (0.0105 lb/bale), respectively. The PSDs were characterized by an average MMD of $29.8 \mu\text{m}$ AED. Based on system average emission factors, the ratio of $\text{PM}_{2.5}$ to total particulate was 1.04%, PM_6 to total particulate was 11.4%, and PM_{10} to total particulate was 20.9%. PSD-based system average $\text{PM}_{2.5}$ and PM_{10} emission factors were 4.6% and 27% of those measured for overall cotton gin sampling project utilizing EPA-approved methods. The PSD-based PM_{10} emission factor was 4% that currently published in EPA AP-42 for lint cleaners, which is equivalent to combined 1st and 2nd stage lint cleaning system exhausts. Currently there are no 2nd stage lint cleaning system emission factors published EPA AP-42.

ACKNOWLEDGMENTS

The authors appreciate the cooperating gin managers and personnel who generously allowed and endured sampling at their gins. In addition, we thank California Cotton Ginners' and Growers' Association, Cotton Incorporated, San Joaquin Valleywide Air Pollution Study Agency, Southeastern Cotton Ginners' Association, Southern Cotton Ginners' Association, Texas Cotton Ginners' Association, Texas State Support Committee, and The Cotton Foundation for funding this project. This project was supported in-part by the USDA National Institute of Food and Agriculture Hatch Project OKL02882. The authors also thank the Cotton Gin Advisory Group and Air Quality Advisory Group for their involvement and participation in planning, execution, and data analyses for this project that is essential to developing quality data that will be used by industry, regulatory agencies, and the scientific community. The advisory groups included: the funding agencies listed above, California Air Resources Board, Missouri Department of Natural Resources, National Cotton Council, National Cotton Ginners' Association, North Carolina Department of Environment and Natural Resources, San Joaquin Valley Air Pollution Control District, Texas A&M University, Texas Commission on Environmental Quality, USDA-NRCS National Air Quality and Atmospheric Change, and U.S. Environmental Protection Agency (National, Region 4 and 9).

DISCLAIMER

Mention of trade names or commercial products in this publication is solely for the purpose of providing specific information and does not imply recommendation or endorsement by the Oklahoma State University or U.S. Department of Agriculture. Oklahoma State University and USDA are equal opportunity providers and employers.

REFERENCES

- Barber, E.M., J.R. Dawson, V.A. Battams, R.A.C. Nicol. 1991. Spatial variability of airborne and settled dust in a pig-gery. *J. Agric. Eng. Res.* 50(2):107–127.
- Beckman Coulter. 2011. Coulter LS Series: Product Manual. Beckman Coulter, Brea, CA.

- Boac, J.M., R.G. Maghirang, M.E. Casada, J.D. Wilson, Y.S. Jung. 2009. Size distribution and rate of dust generated during grain elevator handling. *Appl. Eng. Agric.* 25(4):533–541.
- Boykin, J.C., M.D. Buser, D.P. Whitelock, and G.A. Holt. 2013. Second stage lint cleaning system PM_{2.5} emission factors and rates from cotton gins: Method 201A combination PM₁₀ and PM_{2.5} sizing cyclones. *J. Cotton Sci.* 17(4):380–390.
- Buser, M.D. 2004. Errors associated with particulate matter measurements on rural sources: appropriate basis for regulating cotton gins. Ph.D. diss. Texas A&M Univ., College Station.
- Buser, M.D. and D.P. Whitelock. 2007. Preliminary field evaluation of EPA Method CTM-039 (PM_{2.5} stack sampling method). 10 pp. *In Proc. World Cotton Conf.* 4, Lubbock, TX. 10–14 Sep, 2007. International Cotton Advisory Committee, Washington, D.C.
- Buser, M.D., C.B. Parnell Jr., B.W. Shaw, and R.E. Lacey. 2007a. Particulate matter sampler errors due to the interaction of particle size and sampler performance characteristics: background and theory. *Trans. ASABE.* 50(1):221–228.
- Buser, M.D., C.B. Parnell Jr., B.W. Shaw, and R.E. Lacey. 2007b. Particulate matter sampler errors due to the interaction of particle size and sampler performance characteristics: ambient PM_{2.5} samplers. *Trans. ASABE.* 50(1):241–254.
- Buser, M.D., C.B. Parnell Jr., B.W. Shaw, and R.E. Lacey. 2007c. Particulate matter sampler errors due to the interaction of particle size and sampler performance characteristics: ambient PM₁₀ samplers. *Trans. ASABE.* 50(1):229–240.
- Buser, M.D., D.P. Whitelock, J.C. Boykin, and G.A. Holt. 2012. Characterization of cotton gin particulate matter emissions—project plan. *J. Cotton Sci.* 16(2):105–116.
- Buser, M.D., D.P. Whitelock, J.C. Boykin, and G.A. Holt. 2015. Second stage lint cleaning system total particulate emission factors and rates from cotton gins: Method 17. *J. Cotton Sci.* 19:82–91.
- Buurman, P., Th. Pape, J.A. Reijneveld, F. de Jong, and E. van Gelder. 2001. Laser-diffraction and pipette-method grain sizing of Dutch sediments: correlations for fine fractions of marine, fluvial, and loess samples. *Neth. J. Geosci.* 80(2):49–57.
- Code of Federal Regulations (CFR). 1978. Method 17—Determination of particulate emissions from stationary sources (in-stack filtration method). 40 CFR 60 Appendix A-6. Available at <http://www.epa.gov/ttn/emc/promgate/m-17.pdf> (verified 20 May 2015).
- Code of Federal Regulations (CFR). 2010. Method 201A—Determination of PM₁₀ and PM_{2.5} emissions from stationary sources (Constant sampling rate procedure). 40 CFR 51 Appendix M. Available at <http://www.epa.gov/ttn/emc/promgate/m-201a.pdf> (verified 20 May 2015).
- Code of Federal Regulations (CFR). 2013. National ambient air quality standards for particulate matter; final rule. 40 CFR, Part 50. Available at <http://www.gpo.gov/fdsys/pkg/FR-2013-01-15/pdf/2012-30946.pdf> (verified 20 May 2015).
- Environmental Protection Agency (EPA). 1996a. Emission factor documentation for AP-42, Section 9.7, Cotton Ginning, (EPA Contract No. 68-D2-0159; MRI Project No. 4603-01, April 1996). Publ. AP-42. U.S. Environmental Protection Agency, Washington, DC.
- Environmental Protection Agency (EPA). 1996b. Food and agricultural industries: cotton gins. *In Compilation of Air Pollution Emission Factors. Vol. 1. Stationary Point and Area Sources.* Publ. AP-42. U.S. Environmental Protection Agency, Washington, DC.
- Environmental Protection Agency (EPA). 1996c. Appendix B.1 Particle size distribution data and sized emission factors for selected sources. *In Compilation of Air Pollution Emission Factors. Vol. 1. Stationary Point and Area Sources.* Publ. AP-42. U.S. Environmental Protection Agency, Washington, DC.
- Faulkner, W.B., L.B. Goodrich, V.S. Botlaguduru, S.C. Capareda, and C.B. Parnell. 2009. Particulate matter emission factors for almond harvest as a function of harvester speed. *J. Air Waste Manag. Assoc.* 59(8):943–949.
- Hinds, W.C. 1982. *Aerosol Technology; Properties, Behavior and Measurement of Airborne Particles.* 1st Ed. Wiley-Interscience, New York, NY.
- Hughs, S.E., and P.J. Wakelyn. 1997. Physical characteristics of cyclone particulate emissions. *Appl. Eng. Agric.* 13(4):531–535.
- Hughs, S.E., M.N. Gillum, and B.M. Armijo. 1982. Collecting particles from gin lint cleaner air exhausts. *Trans. ASAE.* 25(5):1435N1438.
- Hughs, S.E., P.J. Wakelyn, M.A. Rousselle, and E.P. Columbus. 1997. Chemical composition of cotton gin external emissions: proximate and elemental analysis. *Trans. ASAE.* 40(3):519–527.
- Lacey, R.E., J.S. Redwine, and C.B. Parnell, Jr. 2003. Particulate matter and ammonia emission factors for tunnel-ventilated broiler production houses in the Southern U.S. *Trans. ASABE.* 46(4):1203–1214.

- National Agricultural Statistics Service (NASS). 2001. Cotton Ginnings Annual Summary [Online]. USDA National Agricultural Statistics Service, Washington, DC. Available at <http://usda.mannlib.cornell.edu/usda/nass/CottGinnSu//2000s/2001/CottGinnSu-05-10-2001.pdf> (verified 20 May 2015).
- National Agricultural Statistics Service (NASS). 2012. Cotton Ginnings Annual Summary [Online]. USDA National Agricultural Statistics Service, Washington, DC. Available at <http://usda.mannlib.cornell.edu/usda/nass/CottGinnSu//2010s/2012/CottGinnSu-05-10-2012.pdf> (verified 20 May 2015).
- Sweeten, J.M., C.B. Parnell Jr., B.W. Shaw, and B.W. Auverman. 1998. Particle size distribution of cattle feedlot dust emission. *Trans. ASABE*. 41(5):1477–1481.
- Valco, T.D., H. Ashley, J.K. Green, D.S. Findley, T.L. Price, J.M. Fannin, and R.A. Isom. 2012. The cost of ginning cotton—2010 survey results. p. 616–619 *In Proc. Beltwide Cotton Conference, Orlando, FL 3-6 Jan. 2012.* Natl. Cotton Counc. Am., Cordova, TN.
- Valco, T.D., B. Collins, D.S. Findley, J.K. Green, L. Todd, R.A. Isom, and M.H. Wilcutt. 2003. The cost of ginning cotton—2001 survey results. p. 662–670 *In Proc. Beltwide Cotton Conference, Nashville, TN 6-10 Jan. 2003.* Natl. Cotton Counc. Am., Memphis, TN.
- Valco, T.D., J.K. Green, R.A. Isom, D.S. Findley, T.L. Price, and H. Ashley. 2009. The cost of ginning cotton—2007 survey results. p. 540–545 *In Proc. Beltwide Cotton Conference, San Antonio, TX 5-8 Jan. 2009.* Natl. Cotton Counc. Am., Cordova, TN.
- Valco, T.D., J.K. Green, T.L. Price, R.A. Isom, and D.S. Findley. 2006. Cost of ginning cotton—2004 survey results. p. 618–626 *In Proc. Beltwide Cotton Conference, San Antonio, TX 3-6 Jan. 2006.* Natl. Cotton Counc. Am., Memphis, TN.
- Wang-Li, L., Z. Cao, M. Buser, D. Whitelock, C.B. Parnell, and Y. Zhang. 2013. Techniques for measuring particle size distribution of particulate matter emitted from animal feeding operations. *J. Atmos. Environ.* 66(2013):25–32.
- Wakelyn, P.J., D.W. Thompson, B.M. Norman, C.B. Nevius, and D.S. Findley. 2005. Why cotton ginning is considered agriculture. Cotton Gin and Oil Mill Press. 106(8):5–9.
- Wesley, R., W. Mayfield, and O. McCaskill. 1972. An evaluation of the cyclone collector for cotton gins. Tech. Bull. No. 1439. USDA Agricultural Research Service, Beltsville, MD.
- Whitelock, D.P., M.D. Buser, J.C. Boykin, and G.A. Holt. 2014. Second stage lint cleaning system PM₁₀ emission factors and rates from cotton gins: Method 201A PM₁₀ sizing cyclones. *J. Cotton Sci.* 18(2):237–247.
- Whitelock, D.P., C.B. Armijo, M.D. Buser, and S.E. Hughs. 2009. Using cyclones effectively at cotton gins. *Appl. Eng. Ag.* 25(4):563–576.