

ENGINEERING AND GINNING

Second Stage Seed-Cotton Cleaning System Particulate Emission Factors for Cotton Gins: Particle Size Distribution Characteristics

J. Clif Boykin, Michael D. Buser*, Derek P. Whitelock, and Gregory A. Holt

ABSTRACT

This report is part of a project to characterize cotton gin emissions from the standpoint of total particulate stack sampling and particle size analyses. In 2006 and again in 2013, the United States (U.S.) Environmental Protection Agency (EPA) published a more stringent National Ambient Air Quality Standard for particulate matter with nominal diameter less than or equal to 2.5 μm ($\text{PM}_{2.5}$). This created an urgent need to collect additional cotton gin emissions data to address current regulatory issues, because EPA AP-42 cotton gin $\text{PM}_{2.5}$ emission factors were limited. In addition, current EPA AP-42 emission factor quality ratings for cotton gin PM_{10} (particulate matter with nominal diameter less than or equal to 10 μm) data are questionable, being extremely low. The objective of this study was to characterize particulate emissions for 2nd stage seed-cotton cleaning systems from cotton gins across the cotton belt based on particle size distribution analysis of total particulate samples from EPA-approved stack sampling methods. Average measured $\text{PM}_{2.5}$, PM_6 , and PM_{10} emission factors based on the mass and particle size analyses of EPA Method 17 total particulate filter and wash samples from five gins (14 total test runs) were 0.0014 kg/227-kg bale (0.0031 lb/500-lb bale), 0.015 kg/bale (0.032 lb/bale), and 0.025 kg/bale (0.056 lb/bale), respectively. The 2nd stage seed-cotton cleaning system particle size distributions were characterized by an average

mass median diameter of 12.2 μm (aerodynamic equivalent diameter). Based on system average emission factors, the ratio of $\text{PM}_{2.5}$ to total particulate was 2.42%, PM_6 to total particulate was 25.1%, and PM_{10} to total particulate was 43.2%.

In 2006 and again in 2013, the United States (U.S.) Environmental Protection Agency (EPA) published a more stringent standard for particulate matter (PM) with a particle diameter less than or equal to a nominal 2.5- μm ($\text{PM}_{2.5}$) aerodynamic equivalent diameter (AED) (CFR, 2013). The cotton industry's primary concern with this standard was the limited cotton gin $\text{PM}_{2.5}$ emissions data published in the literature and in EPA's AP-42, Compilation of Air Pollutant Emission Factors (EPA, 1996b). AP-42 was first circulated in 1972 and the last complete document revision was in 1995. Since 1995, only updates and supplements have been added. AP-42 contains air pollutant emission factors for more than 200 industrial sources of air pollution along with information on the processes conducted at these sources.

An emission factor is a relationship between a process and the amount of air pollution emitted by that process into the atmosphere (EPA, 1996b). Emission factors are usually defined as the weight of pollutant emitted per unit weight, volume, distance, or duration of the activity producing the pollutant (e.g., kilogram of particulate emitted per cotton bale ginned). These relationships have been established from source test data, modeling, material balance studies, and engineering estimates and are usually averages of all data that have been gathered for a particular process (EPA, 1996a).

EPA's AP-42 was developed to include emission factors for all criteria pollutants and additional pollutants beyond the scope of the National Ambient Air Quality Standards (NAAQS), including total PM, PM_{10} (PM with a particle diameter less than or equal to a nominal 10- μm AED), and $\text{PM}_{2.5}$. Current AP-42 cotton gin emission factors are located in section 9.7 (EPA, 1996b). Further, Appendix B.1 of AP-42 contains particle size distribution (PSD)

J.C. Boykin, USDA-ARS Cotton Ginning Research Unit, 111 Experiment Station Road, P.O. Box 256, Stoneville, MS 38776; M.D. Buser*, Biosystems and Agricultural Engineering, Oklahoma State University, 111 Agricultural Hall, Stillwater, OK 74078; D.P. Whitelock, USDA-ARS Southwestern Cotton Ginning Research Laboratory, 300 E College Dr., P.O. Box 578, Mesilla Park, NM 88047; and G.A. Holt, USDA-ARS Cotton Production and Processing Research Unit, 1604 E. FM 1294, Lubbock, TX 79403

*Corresponding author: buser@okstate.edu

data and emission factors based on these PSDs (EPA, 1996c). The only PM_{2.5} emission factors in the current AP-42 were listed in Appendix B.1 and were based on PSDs. The 1996 AP-42 version only contained cotton ginning PSD data for the battery condenser and combined lint cleaning systems. The information for the battery condenser system equipped with cyclones was based on two tests and the PSD data was determined using a UW Mark 3 Impactor. The information for the combined lint cleaning system equipped with cyclones was based on four tests. The total particulate concentration data was determined using EPA Method 5 and the PSD data was determined by using a Coulter Counter to process the Method 5 samples (Hughes et al., 1982). Hughes et al. (1982) did not specifically state whether the PSD results were based on both the Method 5 wash and filter samples, wash only, or filter only. Table 1 provides examples of the types of data that were provided in EPA's AP-42 Appendix B.1.

Emission factors from EPA AP-42 developed prior to 2013 were assigned ratings to assess the quality of the data being referenced. The ratings ranged from A (excellent) to E (poor). The PSD data quality rating in the 1996 AP-42 for both the battery condenser and combined lint cleaning systems was E (EPA, 1996c).

Cotton ginners' associations across the U.S. cotton belt, including the National, Texas, Southern, Southeastern, and California associations, agreed that there was an urgent need to collect additional PSD data on PM being emitted from cotton ginning system exhausts. Working with cotton ginning associations across the country, state and federal regulatory agencies, Oklahoma State University, and USDA-Agricultural Research Service (ARS) researchers developed a proposal and sampling plan that was initiated in 2008 to address this need. Buser et al. (2012) provided the details of this sampling plan. This article is part of a series that details cotton gin emission factors developed from coupling total particulate stack sampling concentrations and particle size analyses. Each manuscript in the series

addresses a specific cotton ginning system. The systems covered in the series include: unloading, 1st stage seed-cotton cleaning, 2nd stage seed-cotton cleaning, 3rd stage seed-cotton cleaning, overflow, 1st stage lint cleaning, 2nd stage lint cleaning, combined lint cleaning, cyclone robber, 1st stage mote, 2nd stage mote, combined mote, mote cyclone robber, mote cleaner, mote trash, battery condenser, and master trash. This manuscript reports on the characterization of PM_{2.5} and PM₁₀ emissions from 2nd stage seed-cotton cleaning systems.

Cotton Ginning. Seed cotton is a perishable commodity that has no real value until the fiber and seed are separated (Wakelyn et al., 2005). Cotton must be processed or ginned at the cotton gin to separate the fiber and seed, producing 227-kg (500-lb) bales of marketable cotton fiber. Cotton ginning is considered an agricultural process and an extension of the harvest by several federal and state agencies (Wakelyn et al., 2005). Although the main function of the cotton gin is to remove the lint fiber from the seed, many other processes occur during ginning, such as cleaning, drying, and packaging the lint. Pneumatic conveying systems are the primary method of material handling in a cotton gin. As material reaches a processing point, the conveying air is separated and emitted outside the gin through a pollution control device. The amount of PM emitted by a system varies with the process and the composition of the material being processed.

Cotton ginning is a seasonal industry with the ginning season lasting from 75 to 120 days, depending on the crop size and condition. Although the general trend for U.S. cotton production has remained constant at about 17 million bales per year during the last 20 years, production from year to year often varies greatly for various reasons, including climate and market pressure. The number of active gins in the U.S. has not remained constant, steadily declining from 1,018 in 2000 to 682 in 2011 (NASS, 2001, 2012). Consequently, the average cotton gin production capacity across the U.S. cotton belt has increased to an approximate average of 25 bales per hour (Valco et al., 2003, 2006, 2009, 2012).

Table 1. EPA AP-42 Appendix B.1 particle size distribution data for the battery condenser and combined lint cleaning systems equipped with cyclones on the system exhausts.

System	% < 2.5 μm	Emission Factor kg/bale	% < 6.0 μm	Emission Factor kg/bale	% < 10 μm	Emission Factor kg/bale
Lint cleaner	1	Not Reported	20	Not Reported	54	Not Reported
Battery condenser	8	0.007	33	0.028	62	0.053

Typical cotton gin processing systems include: unloading, dryers, seed-cotton cleaners, gin stands, overflow, lint cleaners, battery condenser, bale packaging, and trash handling (Fig. 1); however, the number and type of machines and processes can vary. Each of these systems serves a unique function with the ultimate goal of ginning the cotton to produce a marketable product. Raw seed cotton harvested from the field is compacted into large units called “modules” for delivery to the gin. The unloading system removes seed cotton either mechanically or pneumatically from the module feeding system and conveys the seed cotton to the cleaning systems. Seed-cotton cleaning systems assist in drying the seed cotton and removing foreign matter prior to ginning. Ginning systems also remove foreign matter and separate the cotton fiber from seed. Lint cleaning systems further clean the cotton lint after ginning. The battery condenser and packaging systems combine lint from the lint cleaning systems and compress the lint into dense bales for efficient transport. Gin systems produce by-products or trash, such as rocks, soil, sticks, hulls, leaf material, and short or tangled immature fiber (motes), as a result of processing the seed cotton or lint. These streams of by-products must be removed from the machinery and handled by trash collection systems. These trash systems typically further process the by-products (e.g., mote cleaners) and/or consolidate the trash from the gin systems into a hopper or pile for subsequent removal.

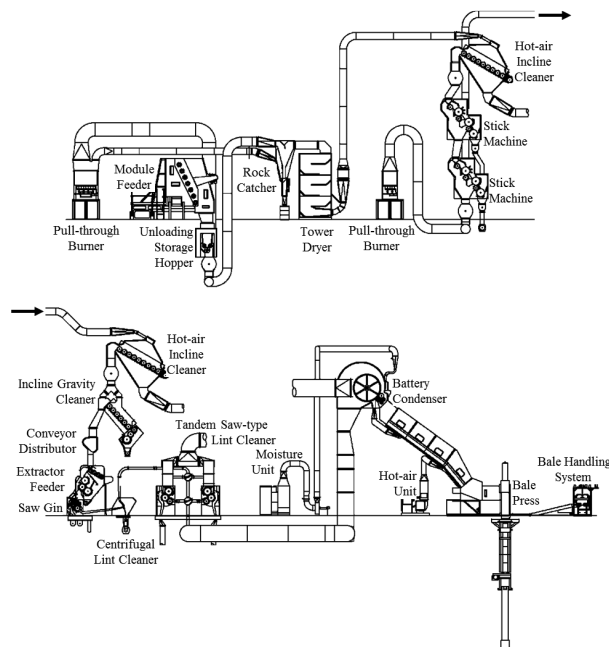

Figure 1. Typical modern cotton gin layout (Courtesy Lummus Corporation, Savannah, GA).

The seed cotton is cleaned and dried in the seed-cotton cleaning systems. In the typical 2nd stage seed-cotton cleaning system (Fig. 2), seed cotton drops from the 1st stage seed-cotton cleaning system machinery into the hot air pneumatic conveying system of the 2nd stage seed-cotton cleaning system via a rotary airlock and blow box. The seed cotton is pulled directly into the 2nd stage seed-cotton cleaning machinery and separated from the conveying airstream by the cleaning mechanism (called a hot-air cleaner) or separated from the conveying air via a screened separator and dropped into the cleaning machinery. Seed-cotton cleaning machinery includes cylinder cleaners or extractors. Each stage often employs two cleaners in series. This system removes foreign matter that includes rocks, soil, sticks, hulls, and leaf material. The airstream from the 2nd stage seed-cotton cleaning system continues through a centrifugal fan to an abatement system; generally one or more cyclones. This cleaning system might use air heated up to 117°C (350°F) at the seed cotton and air mixing point to accomplish drying during transport (ASABE, 2007). Based on system configuration, the airstream temperature at the abatement device could range from ambient to about 50% of the mixing-point temperature. The material handled by the abatement system is typically the same as that removed by the seed-cotton cleaning machinery (rocks, soil, sticks, hulls, and leaf material) and lint extracted with the trash (Fig. 3).

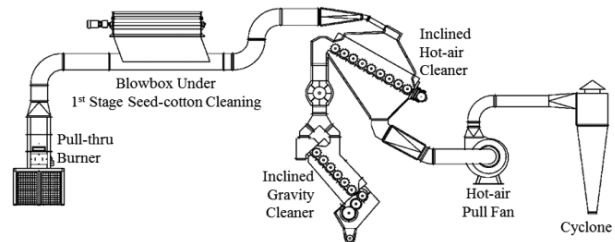

Figure 2. Typical cotton gin 2nd stage seed-cotton cleaning system layout (Courtesy Lummus Corporation, Savannah, GA).



Figure 3. Photograph of typical trash captured by the 2nd stage seed-cotton cleaning system cyclones.

Cyclones. Cyclones are the most common PM abatement devices used at cotton gins. Standard cyclone designs used at cotton ginning facilities are the 2D2D and 1D3D (Whitelock et al., 2009). The first D in the designation indicates the length of the cyclone barrel relative to the cyclone barrel diameter. The second D indicates the length of the cyclone cone relative to the cyclone barrel diameter. A standard 2D2D cyclone (Fig. 4) has an inlet height of $D/2$ and width of $D/4$ and design inlet velocity of 15.2 ± 2 m/s (3000 ± 400 fpm). The standard 1D3D cyclone (Fig. 4) has the same inlet dimensions as either the 2D2D or the original 1D3D inlet with height of D and width $D/8$. Also, it has a design inlet velocity of 16.3 ± 2 m/s (3200 ± 400 fpm).

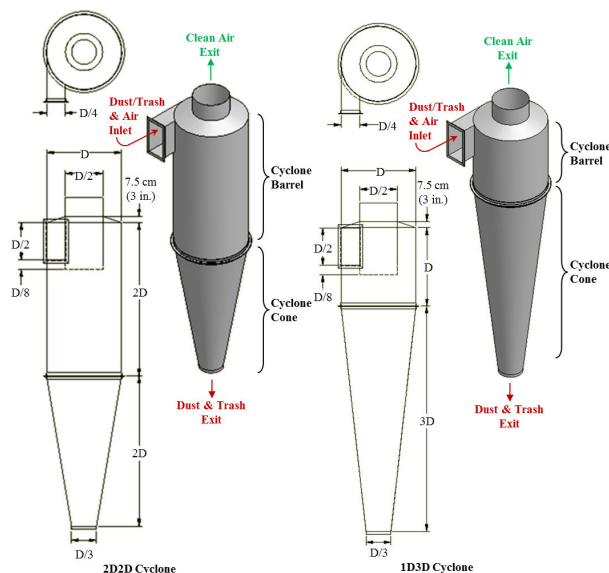

Figure 4. 2D2D and 1D3D cyclone schematics.

Cotton Gin Emission Factors. EPA emission factors for cotton gins are published in EPA's Compilation of Air Pollution Emission Factors, AP-42 (EPA, 1996a). The AP-42 average total particulate emission factor for the No. 2 dryer and cleaner, which is an equivalent system to the 2nd stage seed-cotton cleaning system, was 0.11 kg (0.24 lb) per 217-kg (480-lb) equivalent bale with a range of 0.047 to 0.36 kg (0.10 to 0.79 lb) per bale (EPA, 1996a, b). This average and range were based on seven tests conducted in one geographical location. The EPA emission factor quality rating was D, which is the second lowest possible rating (EPA, 1996a). The AP-42 average PM_{10} emission factor for the No. 2 dryer and cleaner was 0.043 kg (0.093 lb) per 217-kg (480-lb) equivalent bale with a range of 0.018 to 0.11 kg (0.040-0.23 lb) per bale (EPA, 1996a, b). This

average and range were based on five tests conducted in one geographical location, and the EPA emission factor quality rating was D. Currently there are no $PM_{2.5}$ emission factor data listed in the EPA AP-42 for cotton gin 2nd stage seed-cotton cleaning systems.

Buser et al. (2012) discussed the plan of a large-scale project focused on developing cotton gin PM emission factors. Part of this project was focused on developing PM emission factors based on EPA-approved methodologies. Three studies focused on 2nd stage seed-cotton cleaning systems evolved out of the Buser et al. (2012) project plan. Buser et al. (2015) reported on one study that used EPA Method 17 (CFR, 1978) to measure total particulate emission factors for the 2nd stage seed-cotton cleaning systems. The system average total particulate emission factor was 0.058 kg (0.129 lb) per 227-kg (500-lb) equivalent bale with a range of 0.031 to 0.081 kg (0.068-0.180 lb) per bale. Whitelock et al. (2014) reported on a second study that used EPA Method 201A (CFR, 2010) with only the PM_{10} sizing cyclone to measure 2nd stage seed-cotton cleaning system PM_{10} and total particulate emission factors. The system average PM_{10} and total particulate emission factors were 0.039 kg/227-kg bale (0.087 lb/500-lb bale) and 0.056 kg/bale (0.0123 lb/bale), respectively. In the third study, reported by Boykin et al. (2013), EPA Method 201A with both the PM_{10} and $PM_{2.5}$ sizing cyclones was used to measure $PM_{2.5}$, PM_{10} , and total particulate emission factors. The average measured $PM_{2.5}$ emission factor was 0.0037 kg/227-kg bale (0.0080 lb/500-lb bale). The PM_{10} and total particulate average emission factors were 0.038 kg/bale (0.084 lb/bale) and 0.063 kg/bale (0.138 lb/bale), respectively.

Particle size distribution analyses have been utilized in conjunction with total particulate sampling methods to calculate PM emissions concentration and factors for agricultural operations for more than 40 years (Wesley et al., 1972). Some examples include: cattle feedlot operations (Sweeten et al., 1998), poultry production facilities (Lacey et al., 2003), nut harvesting operations (Faulkner et al., 2009), grain handling (Boac et al., 2009), swine finishing (Barber et al., 1991), and cotton ginning (Hughs and Wakelyn, 1997). Buser and Whitelock (2007) reported cotton ginning emission concentrations based on EPA-approved $PM_{2.5}$, PM_{10} , and total particulate stack sampling methods and PSD analyses of the total particulate samples coupled with the total particulate concentrations to calculate

PM_{2.5} and PM₁₀ concentrations. The mass median diameter (MMD) of the PM in the samples ranged from 6 to 8 μm . The study results indicated that the PSD and EPA sampler-based PM₁₀ concentrations were in good agreement, whereas the PM_{2.5} EPA sampler concentrations ranged from 5.8 to 13.3 times the PSD-based concentrations.

The primary objective of this study was to develop PSD characteristics for the PM emitted from cotton gin 2nd stage seed-cotton cleaning systems. The secondary objective was to develop PM_{2.5} and PM₁₀ emission factors for cotton gin 2nd stage seed-cotton cleaning systems equipped with cyclones on the system exhausts based on particle size distribution analysis of total particulate samples from EPA-approved stack sampling methods.

METHODS

Seven cotton gins were sampled across the cotton belt for the overall cotton gin sampling project described by Buser et al. (2012). Key factors for selecting specific cotton gins included: 1) facility location (geographically diverse), 2) production capacity (industry representative), 3) processing systems (typical for industry), and 4) particulate abatement technologies (properly designed and maintained 1D3D cyclones). Five of the seven gins were equipped with 2nd stage seed-cotton cleaning systems. The 2nd stage seed-cotton cleaning systems sampled were typical for the industry, but varied among the gins. The 2nd stage seed-cotton cleaning systems at gin A utilized two, separate and parallel, systems. In each of these parallel systems, the seed-cotton material was pneumatically conveyed from the 1st stage seed-cotton cleaning system with heated air through a dryer to a seed-cotton cleaner in the 2nd stage seed-cotton cleaning system. The material was separated from the airstream by the cleaner. The air from each of the parallel 2nd stage seed-cotton cleaning systems then passed through separate fans and exhausted through separate cyclones. The 2nd stage seed-cotton cleaning systems at gin D also utilized two, parallel streams like those at gin A, except the seed-cotton material dropped from the first set of cleaners into a second set. The 2nd stage seed-cotton cleaning system at gin E was also similar to the systems at gin A, except gin E utilized only a single processing stream with a single dryer, seed-cotton cleaner, fan, and cyclone, instead of two,

parallel streams. Gin F utilized two, parallel 2nd stage seed-cotton cleaning systems with two sets of cleaners, similar to gin D, except there were no dryers before the first set of cleaners. Gin G had the simplest 2nd stage seed-cotton cleaning system. At gin G, the seed-cotton material was pneumatically conveyed in a single stream from the 1st stage seed-cotton cleaning system to a seed-cotton cleaner in the 2nd stage seed-cotton cleaning system. The material was separated from the airstream by the cleaner and the air then passed through a fan and exhausted through one or more cyclones. Buser et al. (2015) provided system flow diagrams for the 2nd stage seed-cotton cleaning systems that were tested.

All 2nd stage seed-cotton cleaning systems sampled utilized 1D3D cyclones to control emissions (Fig. 4), but there were some cyclone design variations among the gins. All the gins, except gins A and E, split the system exhaust flow between two cyclones in a dual configuration (side by side as opposed to one behind another). The system airstreams for gins A and E were exhausted through a single cyclone. Inlets on all the 2nd stage seed-cotton cleaning cyclones were 2D2D type, except gin A that had inverted 1D3D inlets. Expansion chambers were present on 2nd stage seed-cotton cleaning cyclones at all gins, except gins E and F that had standard cones. All of the cyclone variations outlined above, if properly designed and maintained, are recommended for controlling cotton gin emissions (Whitelock et al., 2009). The cyclones at gin F had angle-iron welded inside, down the length of the cone. This is occasionally done by cyclone manufacturers for systems with high particulate loading, especially sand, to encourage material to exit the cyclone more quickly and reduce cone wear; this is not a recommended practice. Buser et al. (2015) provided detailed descriptions of the abatement cyclones that were tested.

Method 17 Stack Sampling. The samples utilized for the PSD analyses and gravimetric sample data used in developing the PSD characteristics and PSD-based emission factors were obtained from EPA Method 17 stack testing (CFR, 1978) that was conducted at the five gins with 2nd stage seed-cotton cleaning systems as part of the overall cotton gin sampling project described by Buser et al. (2012). The Method 17 sampling methods and the procedures for retrieving the filter and conducting acetone wash of the sampler nozzle are

described in the EPA Method 17 documentation (CFR, 1978). Further details of the project specific sampling methods, procedures, and results of the EPA Method 17 stack testing were reported by Buser et al. (2015).

Laboratory Analysis. All laboratory analyses were conducted at the USDA-ARS Air Quality Lab (AQL) in Lubbock, TX. All filters were conditioned in an environmental chamber ($21 \pm 2^\circ\text{C}$ [$70 \pm 3.6^\circ\text{F}$]; $35 \pm 5\%$ RH) for 48 h prior to gravimetric analyses. Filters were weighed in the environmental chamber on a Mettler MX-5 microbalance (Mettler-Toledo Inc., Columbus, OH; $1 \mu\text{g}$ readability and $0.9 \mu\text{g}$ repeatability) after being passed through an antistatic device. The MX-5 microbalance was leveled on a marble table and housed inside an acrylic box to minimize the effects of air currents and vibrations. To reduce recording errors, weights were digitally transferred from the microbalance directly to a spreadsheet. Technicians wore latex gloves and a particulate respirator mask to avoid contaminating the filter or sample. AQL procedures required that each sample be weighed three times. If the standard deviation of the weights for a given sample exceeded $10 \mu\text{g}$, the sample was reweighed. Gravimetric procedures for the acetone wash tubs were the same as those used for filters.

In addition to gravimetric analyses, each sample was visually inspected for unusual characteristics, such as cotton lint content or extraneous material. Digital pictures were taken of all filters and washes for documentation purposes. After the laboratory analyses were completed all stack sampling, cotton gin production, and laboratory data were merged.

Particle Size Analysis. A Beckman Coulter LS230 laser diffraction system (Beckman Coulter Inc., Miami, FL) with software version 3.29 was used to perform the particle size analyses on the filter and wash samples. The instrument sizes particles with diameters ranging from 0.4 to $2000 \mu\text{m}$. For this project, the LS230 fluid module was used with a 5% lithium chloride/methanol suspension fluid mixture. Approximately 10-L batches of the suspension fluid were prepared and stored in a self-contained, recirculating, filtration system equipped with $0.2 \mu\text{m}$ filters to keep the fluid well mixed and free of larger particles. Prior to each test run a background particle check was performed on the fluid to help minimize particulate contamination from non-sample sources. The process of analyzing the samples included the following steps:

1. pour approximately 40 mL of clean suspension fluid into a clean 100-mL beaker;
2. transfer a particulate sample to the 100-mL beaker with clean suspension fluid,
 - a. for 47-mm filter media, remove the filter from the Petri dish with tweezers and place the filter in the 100-mL beaker with the suspension fluid,
 - b. for the wash samples contained in a sample tub, use a small amount of the suspension fluid and a sterile foam swab to transfer the sample from the tub to the 100-mL beaker;
3. place the 100-mL beaker in an ultrasonic bath for 5 min to disperse the PM sample in the fluid;
4. using a sterile pipette, gradually introduce the PM and suspension fluid mixture into clean suspension fluid that is being monitored by the LS230 until an obscuration level of 10% is reached;
5. activate the LS230 system to measure the diffraction patterns and calculate the PSD;
6. repeat step 5 a total of three times and average the results; and
7. drain and flush/clean the LS230 system.

Optical models for calculating laser diffraction-based PSDs require input of a refractive index for the suspension fluid and real and imaginary refractive indices for the sample. A refractive index of 1.326 for methanol was used for the suspension fluid (Beckman Coulter, 2011). Hughs et al. (1997) showed that particulate from cyclone exhausts was about 34% ash or fine soil particulate with the balance made up of water and organic material (e.g., cellulose, lignin, protein). Real and imaginary refractive index values for common soil constituents—quartz, clay minerals, silica and feldspars—are 1.56 and 0.01, respectively (Buurman et al., 2001). These indices were used in the optical model used in calculating the PSD for the cyclone particulate samples. Wang-Li et al. (2013) and Buser (2004) provided additional details on the PSD methodology.

The LS230 PSD results are in the form of particle volume versus equivalent spherical diameter. The PSD results were converted to particle volume versus AED using the following equation:

$$d_a = d_p \left(\frac{\rho_p}{\kappa \rho_w} \right)^{1/2}$$

where ρ_w is the density of water with a value of 1 g/cm^3 , ρ_p is the particle density, and κ is the dynamic shape factor. The dynamic shape factor was determined to be 1.4 based on Hinds (1982) factors for quartz and sand dust. The particle density, assumed to be constant for the Method 17 filter and wash samples evaluated in this study, was determined in an earlier study to be 2.65 g/cm^3 (M. Buser, unpublished data, 2013). This earlier study used a helium displacement AccuPyc 1330 Pycnometer (Micromeritics, Norcross, GA) to determine the particle density of cotton gin waste that passed through a No. 200 sieve (particles that pass through a $74\text{-}\mu\text{m}$ sieve opening). The study was based on three random samples collected at 43 different cotton gins.

Results obtained from each average adjusted PSD included: MMD, mass fraction of PM with diameter less than or equal to $10 \mu\text{m}$ (PM_{10}), mass fraction of PM with diameter less than or equal to $6 \mu\text{m}$ (PM_6), and mass fraction of PM with diameter less than or equal to $2.5 \mu\text{m}$ ($\text{PM}_{2.5}$). This information was coupled with the corresponding Method 17 sample mass to calculate the PM_{10} , PM_6 , and $\text{PM}_{2.5}$ emission factors using the following equation:

$$EF_i = EF_{tot} \left(\left(\frac{M_F}{M_F + M_W} \right) w_{Fi} + \left(\frac{M_W}{M_F + M_W} \right) w_{Wi} \right)$$

where EF_i = emission factor for particle in the size range i ;

EF_{tot} = total particulate emission factor obtained from total particulate tests (Buser et al., 2015);

M_F = total mass of particulate on filter;

M_W = total mass of particulate in nozzle wash;

w_{Fi} = mass fraction of particles on the filter in the size range i ; and

w_{Wi} = mass fraction of particles in the nozzle wash in the size range i .

The 2nd stage seed-cotton cleaning systems sampled were typical for the industry. The system average ginning rate was 34.7 bales/h and the test average ginning rate at each gin ranged from 21.2 to 49.8 bales/h (based on 227-kg [500-lb] equivalent bales). The capacity of gins sampled was representative of the industry average, approximately 25 bales/h. The 1D3D cyclones were all operated with inlet velocities within design criteria, 16.3 ± 2

m/s (3200 ± 400 fpm), except the test runs at gin D and two runs at gin F that were outside the design range due to limitations in available system adjustments. The first run at gin F was omitted from the test averages because of ginning issues; extremely low ginning rate. There are criteria specified in EPA Method 17 for test runs to be valid for total particulate measurements (CFR, 1978). Isokinetic sampling must fall within EPA-defined range of $100 \pm 10\%$. All tests met the isokinetic criteria. The stack gas temperatures ranged from 23 to 70°C ($73\text{-}157^\circ\text{F}$) and moisture content ranged from 0.1 to 3.3%. The individual systems and cyclone design variations were discussed by Buser et al. (2015).

RESULTS

The PSD characteristics and mass of the PM captured on the filters are shown in Table 2. The mass of the PM captured on the filter accounted for 66 to 98% of the total PM (filter and wash) collected from the individual test runs. The system average MMD for particulate on the filters was $10.6 \mu\text{m}$ AED. Test averages ranged from 6.5 to $15.2 \mu\text{m}$ AED. The test and system averages are based on averaging PSDs and not averaging individual test results. The mass fraction of $\text{PM}_{2.5}$, PM_6 , and PM_{105} ranged from 0.96 to 5.54%, 18.7 to 46.3%, and 36.3 to 70.1%, respectively. Filter PM PSDs for the five gins and the system average are shown in Fig. 5. In general, the PSD characteristics for the PM captured on the filters for the gins were consistent. The PSD for gins A and D were shifted left compared to gins E, F, and G. This reflects the lower MMD and larger percentage of smaller particulate in the samples from gins A and D.

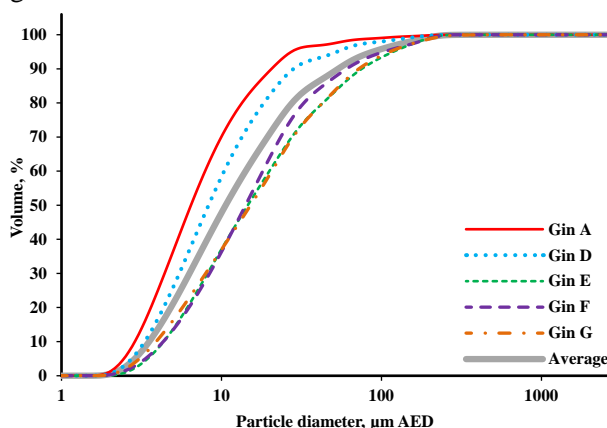

Figure 5. Gin average cumulative particle size distributions for the PM captured on a EPA-Method 17 filter from the 2nd stage seed-cotton cleaning systems.

Table 2. EPA Method 17 filter particle size distribution data for the 2nd stage seed-cotton cleaning system.

Gin	Test Run	Mass Median Diameter µm AED	PM _{2.5} %	PM ₆ %	PM ₁₀ %	Sample Total mg
A	1	6.0	6.08	49.6	74.1	25.92
	2	6.3	6.25	47.5	69.5	27.73
	3	7.1	4.29	41.7	66.6	32.42
	Test Average (n = 3) ^y	6.5	5.54	46.3	70.1	
D	1	8.0	3.51	36.1	60.4	24.42
	2	8.5	2.85	33.4	57.3	21.63
	3	8.5	3.22	34.0	57.2	17.11
	Test Average (n = 3) ^y	8.3	3.19	34.5	58.3	
E	1	14.6	1.08	20.1	37.5	68.29
	2	14.3	1.18	20.7	38.3	63.30
	3	14.9	0.61	17.3	35.4	64.04
	Test Average (n = 3) ^y	14.6	0.96	19.4	37.1	
F	1 ^z	14.2	1.17	18.1	35.9	3.46
	2	13.2	1.68	19.7	38.4	34.85
	3	15.2	1.31	17.7	34.2	25.23
	Test Average (n = 2) ^y	14.1	1.49	18.7	36.3	
G	1	13.8	2.38	24.0	40.1	65.23
	2	16.2	1.90	20.1	35.0	56.43
	3	15.6	1.76	20.4	35.8	48.72
	Test Average (n = 3) ^y	15.2	2.02	21.5	37.0	
System Average (n = 5) ^y		10.6	2.64	28.1	47.7	

^z Test run omitted from test averages because of ginning issues

^y Based on averaged particle size distributions

The PSD characteristics and mass of the PM captured in the washes are shown in Table 3. The mass of the PM captured in the wash was about 2 to 34% of the total PM (filter and wash) collected from the individual test runs. The system average MMD was 21.2 µm AED. Test average MMDs ranged from 16.7 to 38.5 µm AED. The mass fraction of PM_{2.5}, PM₆, and PM₁₀ ranged from 1.09 to 2.87%, 11.5 to 19.3%, and 18.8 to 33.4%, respectively. PSDs for the PM captured in the nozzle for the five gins and the system average are shown in Fig. 6. In general, the PSDs for the PM captured in the nozzle had larger MMDs (illustrated by the shift to the right of the curves) than the PM captured on the filter. The average test run wash PSDs for gin D, E, F, and G were consistently distributed as shown in Fig. 6. The test average PSD for gin A was shifted to the right with a spike at about 57 µm and an MMD of 38.5 µm.

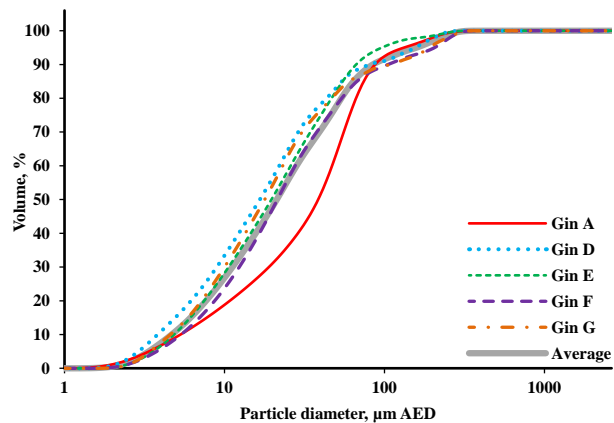

Figure 6. Gin average cumulative particle size distributions for the PM captured in the EPA-Method 17 sampler nozzle wash from the 2nd stage seed-cotton cleaning systems.

The combined PSD characteristics for the PM captured on the filter and PM captured in the wash are shown in Table 4. The 2nd stage seed-cotton cleaning system average combined filter and wash

PSD MMD was 12.2 μm AED (8.9 to 15.3 μm test average range). There were no particles less than 0.8 μm and less than 0.01% of the particles had a diameter of 1 μm or smaller. The combined filter and wash $\text{PM}_{2.5}$, PM_6 , and PM_{10} mass fractions ranged from 0.98 to 4.54%, 17.9 to 35.2%, and 34.9 to 54.2%, respectively. Combined PM PSDs for the five gins and the system average are shown in Fig. 7. In general, the PSD characteristics for the combined filter and nozzle wash PM for the gins were consistent. These combined PSDs are more consistent with the filter PSDs than the wash PSDs. This was expected because the majority of the PM mass was captured on the filter as compared to the nozzle wash.

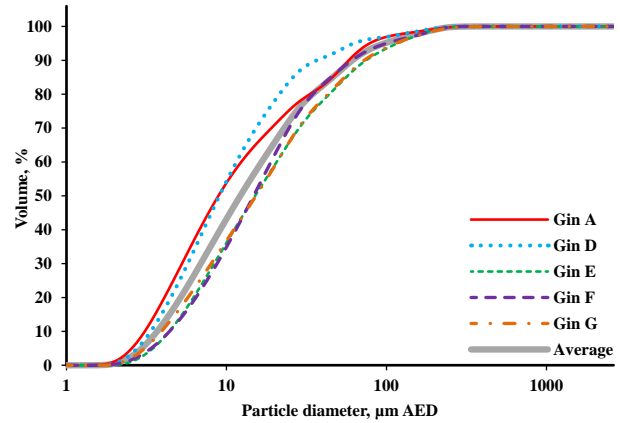

Figure 7. Gin average cumulative particle size distributions for the EPA-Method 17 combined filter and wash samples from the 2nd stage seed-cotton cleaning systems.

Table 3. EPA Method 17 nozzle wash particle size distribution data for the 2nd stage seed-cotton cleaning system.

Gin	Test Run	Mass Median Diameter μm AED	$\text{PM}_{2.5}$ %	PM_6 %	PM_{10} %	Sample Total mg
A	1	36.5	2.45	11.7	19.3	13.21
	2	38.3	2.36	12.8	20.7	14.35
	3	40.8	2.60	10.1	16.4	12.13
	Test Average (n = 3) ^y		38.5	2.47	11.5	18.8
D	1	14.7	3.95	22.7	37.5	3.43
	2	17.3	2.40	18.4	32.4	4.53
	3	18.0	2.28	16.8	30.2	3.94
	Test Average (n = 3) ^y		16.7	2.87	19.3	33.4
E	1	22.6	1.33	13.8	26.1	8.70
	2	23.2	1.35	13.4	25.2	7.71
	3	15.3	1.10	16.5	33.3	1.63
	Test Average (n = 3) ^y		19.7	1.26	14.6	28.2
F	1 ^z	11.9	0.29	18.7	41.9	0.96
	2	20.3	1.04	13.3	26.1	1.10
	3	22.5	1.39	10.7	21.3	6.01
	Test Average (n = 2) ^y		21.4	1.21	12.0	23.7
G	1	17.0	1.63	17.1	31.8	2.17
	2	18.3	0.52	14.8	30.0	1.36
	3	18.3	1.13	14.3	28.1	2.01
	Test Average (n = 3) ^y		17.9	1.09	15.4	30.0
System Average (n = 5) ^y		21.2	1.78	14.6	26.8	

^z Test run omitted from test averages because of ginning issues

^y Based on averaged particle size distributions

Table 4. EPA Method 17 combined filter and wash particle size distribution data for the 2nd stage seed-cotton cleaning system.

Gin	Test Run	Mass Median Diameter µm AED	PM _{2.5} %	PM ₆ %	PM ₁₀ %
A	1	8.5	4.86	36.8	55.6
	2	9.1	4.92	35.7	52.8
	3	9.2	3.83	33.1	53.0
	Test Average (n = 3)^y	8.9	4.54	35.2	53.8
D	1	8.4	3.56	34.5	57.6
	2	9.3	2.78	30.8	53.0
	3	9.5	3.04	30.8	52.1
	Test Average (n = 3)^y	9.0	3.13	32.0	54.2
E	1	15.3	1.11	19.4	36.2
	2	15.0	1.20	19.9	36.8
	3	14.9	0.62	17.3	35.3
	Test Average (n = 3)^y	15.1	0.98	18.9	36.1
F	1 ^z	13.6	0.98	18.2	37.2
	2	13.4	1.66	19.5	38.0
	3	16.4	1.32	16.3	31.7
	Test Average (n = 2)^y	14.8	1.49	17.9	34.9
G	1	13.9	2.36	23.8	39.8
	2	16.3	1.87	19.9	34.8
	3	15.7	1.74	20.2	35.5
	Test Average (n = 3)^y	15.3	1.99	21.3	36.7
System Average (n = 5)^y		12.2	2.42	25.1	43.2

^z Test run omitted from test averages because of ginning issues

^y Based on averaged particle size distributions

The PSD-based emission factors for the 2nd stage seed-cotton cleaning systems are shown in Table 5. The system average PM_{2.5} emission factor was 0.0014 kg/227-kg bale (0.0031 lb/500-lb bale). PM_{2.5} emission factors ranged from 0.00041 to 0.0021 kg (0.00089-0.0046 lb) per bale. The 2nd stage seed-cotton cleaning system average PM₆ emission factor was 0.015 kg/bale (0.032 lb/bale). The PM₆ emission factors ranged from 0.0083 to 0.021 kg/bale (0.018-0.046 lb/bale). The 2nd stage seed-cotton cleaning system average PM₁₀ emission factor was 0.025 kg/bale (0.056 lb/bale) and ranged from 0.015 to 0.042 kg (0.033-0.092 lb) per bale. The ratios of PM_{2.5} to total particulate, PM₆ to total particulate, and PM₁₀ to total particulate, based on the system averages, were 2.42, 25.1, and 43.2%, respectively.

The PSD-based 2nd stage seed-cotton cleaning system PM_{2.5} emission factor was approximately 39% of the PM_{2.5} emission factor reported by Boykin et al. (2013) and measured using EPA Method 201A,

0.0037 kg (0.0080 lb) per 227-kg (500-lb) bale. The PSD-based 2nd stage seed-cotton cleaning system PM₁₀ emission factor was 60% of the EPA AP-42 published value for the No. 2 dryer and cleaner system, 0.043 kg (0.093 lb) per bale (EPA, 1996a). Also, the PSD-based system PM₁₀ emission factor was 64% of the Method 201A (PM₁₀ sizing cyclone only) PM₁₀ emission factor reported by Whitelock et al. (2014), 0.039 kg (0.087 lb) per bale. The PSD-based PM₁₀ emission factor was 66% of the Method 201A (PM₁₀ and PM_{2.5} sizing cyclones) PM₁₀ emission factor reported by Boykin et al. (2013), 0.038 kg (0.084 lb) per bale. The differences among the methods could be attributed to several sources. First, due to constraints in the EPA methods, the three studies utilizing Method 17 for total particulate sampling and PSD analyses, Method 201A for PM₁₀ sampling, and Method 201A for PM_{2.5} and PM₁₀ sampling could not be conducted simultaneously. Combined with the fact that emissions from cotton ginning can vary with the condition of incoming

cotton, PM concentrations measured among the three studies could have varied. Second, for reasons described by Buser (2007a, b, c) and documented by Buser and Whitelock (2007), some larger particles could penetrate the Method 201A sampler PM₁₀ or PM_{2.5} sizing cyclones and collect on the filter. Finally, cotton fibers have a cross-sectional diameter much larger than 10 μm and are difficult to scrub out of air streams. These fibers could cycle in the sizing cyclones and pass through to deposit on the filters. This behavior was observed during some of the Method 201A testing where cotton fibers were found in Method 201A sampler washes and on filters (Fig. 8). Currently there are no EPA-approved guidelines to adjust Method 201A PM₁₀ or PM_{2.5} concentration measurements to account for these fibers.

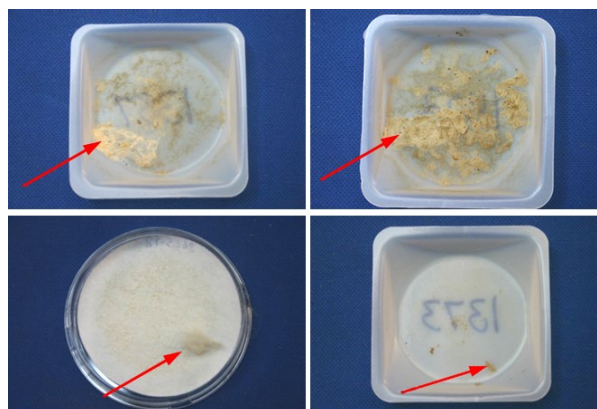

Figure 8. Example EPA Method 201A filter and sampler head acetone washes with lint (indicated by arrows) in the washes and on the filter. Clockwise from top left: > 10 μm wash, 10 to 2.5 μm wash, ≤ 2.5 μm wash, and filter.

Table 5. EPA Method 17 total particulate and particle size distribution based PM_{2.5}, PM₆, and PM₁₀ emission factor data for the 2nd stage seed-cotton cleaning system.

Gin	Test Run	Total ^x		PM _{2.5} ^w		PM ₆ ^w		PM ₁₀ ^w	
		kg/bale ^z	lb/bale ^z	kg/bale ^z	lb/bale ^z	kg/bale ^z	lb/bale ^z	kg/bale ^z	lb/bale ^z
A	1	0.027	0.060	0.0013	0.0029	0.010	0.022	0.015	0.033
	2	0.037	0.082	0.0018	0.0040	0.013	0.029	0.020	0.043
	3	0.028	0.062	0.0011	0.0024	0.0093	0.020	0.015	0.033
D	1	0.048	0.105	0.0017	0.0037	0.016	0.036	0.027	0.060
	2	0.054	0.119	0.0015	0.0033	0.017	0.037	0.029	0.063
	3	0.040	0.088	0.0012	0.0027	0.012	0.027	0.021	0.046
E	1	0.084	0.185	0.00093	0.0021	0.016	0.036	0.030	0.067
	2	0.079	0.175	0.00095	0.0021	0.016	0.035	0.029	0.064
	3	0.066	0.144	0.00041	0.00089	0.011	0.025	0.023	0.051
F	1 ^y	0.112	0.246	0.0011	0.0024	0.020	0.045	0.042	0.092
	2	0.062	0.136	0.0010	0.0023	0.012	0.027	0.023	0.052
	3	0.051	0.112	0.00067	0.0015	0.0083	0.018	0.016	0.035
G	1	0.088	0.194	0.0021	0.0046	0.021	0.046	0.035	0.077
	2	0.068	0.151	0.0013	0.0028	0.014	0.030	0.024	0.052
	3	0.088	0.194	0.0015	0.0034	0.018	0.039	0.031	0.069
System	Average	0.058	0.129	0.0014	0.0031	0.015	0.032	0.025	0.056

^z 227-kg (500-lb) equivalent bales

^y Test run omitted from averages because of ginning issues

^x Taken from Buser et al. (2015)

^w Factors are the product of the corresponding PM percentage from Table 4 and the total particulate emission factor.

SUMMARY

Cotton gins across the U.S. cotton belt were sampled using EPA-approved methods to fill the data gap that exists for PM_{2.5} cotton gin emissions data and to collect additional data to improve the EPA AP-42 total and PM₁₀ emission factor quality ratings for cotton gins. Samples were further

analyzed to characterize the PSD of the particulate measured. Five selected cotton gins had 2nd stage seed-cotton cleaning systems that used pneumatic conveyance and had exhaust airstreams that were not combined with another system. All tested systems were similar in design and typical of the ginning industry and were equipped with 1D3D cyclones for emissions control. In terms of capacity, the five

gins were typical of the industry, averaging 34.7 bales/h during testing. The average PSD-based 2nd stage seed-cotton cleaning system PM_{2.5}, PM₆, and PM₁₀ emission factors from the five gins tested (14 total test runs) were 0.0014 kg/227-kg bale (0.0031 lb/500-lb bale), 0.015 kg/bale (0.032 lb/bale), and 0.025 kg/bale (0.056 lb/bale), respectively. The PSDs were characterized by an average MMD of 12.2 μm AED. Based on system average emission factors, the ratio of PM_{2.5} to total particulate was 2.42%, PM₆ to total particulate was 25.1%, and PM₁₀ to total particulate was 43.2%. PSD-based system average PM_{2.5} and PM₁₀ emission factors were 39% and 64% of those measured for the overall cotton gin sampling project utilizing EPA-approved methods. The PSD-based PM₁₀ emission factor was 60% of that currently published in EPA AP-42 for the No. 2 dryer and cleaner system.

ACKNOWLEDGMENTS

The authors appreciate the cooperating gin managers and personnel who generously allowed and endured sampling at their gins. In addition, we thank California Cotton Ginners' and Growers' Association, Cotton Incorporated, San Joaquin Valleywide Air Pollution Study Agency, Southeastern Cotton Ginners' Association, Southern Cotton Ginners' Association, Texas Cotton Ginners' Association, Texas State Support Committee, and The Cotton Foundation for funding this project. This project was supported in-part by the USDA National Institute of Food and Agriculture Hatch Project OKL02882. The authors also thank the Cotton Gin Advisory Group and Air Quality Advisory Group for their involvement and participation in planning, execution, and data analyses for this project that is essential to developing quality data that will be used by industry, regulatory agencies, and the scientific community. The advisory groups included: the funding agencies listed above, California Air Resources Board, Missouri Department of Natural Resources, National Cotton Council, National Cotton Ginners' Association, North Carolina Department of Environment and Natural Resources, San Joaquin Valley Air Pollution Control District, Texas A&M University, Texas Commission on Environmental Quality, USDA-NRCS National Air Quality and Atmospheric Change, and U.S. Environmental Protection Agency (National, Region 4 and 9).

DISCLAIMER

Mention of trade names or commercial products in this publication is solely for the purpose of providing specific information and does not imply recommendation or endorsement by the Oklahoma State University or U.S. Department of Agriculture. Oklahoma State University and USDA are equal opportunity providers and employers.

REFERENCES

- ASABE. 2007. Temperature Sensor Locations for Seed-Cotton Drying Systems. ASAE S530.1 Aug 2007. American Society of Agricultural and Biological Engineers, St. Joseph, MI.
- Barber, E.M., J.R. Dawson, V.A. Battams, R.A.C. Nicol. 1991. Spatial variability of airborne and settled dust in a pigery. *J. Agric. Eng. Res.* 50(2):107–127.
- Beckman Coulter. 2011. Coulter LS Series: Product Manual. Beckman Coulter, Brea, CA.
- Boac, J.M., R.G. Maghirang, M.E. Casada, J.D. Wilson, Y.S. Jung. 2009. Size distribution and rate of dust generated during grain elevator handling. *Appl. Eng. Agric.* 25(4):533–541.
- Boykin, J.C., M.D. Buser, D.P. Whitelock, and G.A. Holt. 2013. Second stage seed-cotton cleaning system PM_{2.5} emission factors and rates from cotton gins: Method 201A combination PM₁₀ and PM_{2.5} sizing cyclones. *J. Cotton Sci.* 17(4):333–345.
- Buser, M.D. 2004. Errors associated with particulate matter measurements on rural sources: appropriate basis for regulating cotton gins. Ph.D. diss. Texas A&M Univ., College Station.
- Buser, M.D. and D.P. Whitelock. 2007. Preliminary field evaluation of EPA Method CTM-039 (PM_{2.5} stack sampling method). 10 pp. *In Proc. World Cotton Conf.* 4, Lubbock, TX. 10-14 Sep, 2007. International Cotton Advisory Committee, Washington, D.C.
- Buser, M.D., C.B. Parnell Jr., B.W. Shaw, and R.E. Lacey. 2007a. Particulate matter sampler errors due to the interaction of particle size and sampler performance characteristics: background and theory. *Trans. ASABE.* 50(1):221–228.
- Buser, M.D., C.B. Parnell Jr., B.W. Shaw, and R.E. Lacey. 2007b. Particulate matter sampler errors due to the interaction of particle size and sampler performance characteristics: ambient PM_{2.5} samplers. *Trans. ASABE.* 50(1):241–254.

- Buser, M.D., C.B. Parnell Jr., B.W. Shaw, and R.E. Lacey. 2007c. Particulate matter sampler errors due to the interaction of particle size and sampler performance characteristics: ambient PM₁₀ samplers. *Trans. ASABE*. 50(1):229–240.
- Buser, M.D., D.P. Whitelock, J.C. Boykin, and G.A. Holt. 2012. Characterization of cotton gin particulate matter emissions—project plan. *J. Cotton Sci.* 16(2):105–116.
- Buser, M.D., D.P. Whitelock, J.C. Boykin, and G.A. Holt. 2015. Second stage seed-cotton cleaning system total particulate emission factors and rates from cotton gins: Method 17. *J. Cotton Sci.* 19:53–62.
- Buurman, P., Th. Pape, J.A. Reijneveld, F. de Jong, and E. van Gelder. 2001. Laser-diffraction and pipette-method grain sizing of Dutch sediments: correlations for fine fractions of marine, fluvial, and loess samples. *Neth. J. Geosci.* 80(2):49–57.
- Code of Federal Regulations (CFR). 1978. Method 17—Determination of particulate emissions from stationary sources (in-stack filtration method). 40 CFR 60 Appendix A-6. Available at <http://www.epa.gov/ttn/emc/promgate/m-17.pdf> (verified 20 May 2015).
- Code of Federal Regulations (CFR). 2010. Method 201A – Determination of PM₁₀ and PM_{2.5} emissions from stationary sources (Constant sampling rate procedure). 40 CFR 51 Appendix M. Available at <http://www.epa.gov/ttn/emc/promgate/m-201a.pdf> (verified 20 May 2015).
- Code of Federal Regulations (CFR). 2013. National ambient air quality standards for particulate matter; final rule. 40 CFR, Part 50. Available at <http://www.gpo.gov/fdsys/pkg/FR-2013-01-15/pdf/2012-30946.pdf> (verified 20 May 2015).
- Environmental Protection Agency (EPA). 1996a. Emission factor documentation for AP-42, Section 9.7, Cotton Ginning, (EPA Contract No. 68-D2-0159; MRI Project No. 4603-01, April 1996). Publ. AP-42. U.S. Environmental Protection Agency, Washington, DC.
- Environmental Protection Agency (EPA). 1996b. Food and agricultural industries: cotton gins. *In* Compilation of Air Pollution Emission Factors. Vol. 1. Stationary Point and Area Sources. Publ. AP-42. U.S. Environmental Protection Agency, Washington, DC.
- Environmental Protection Agency (EPA). 1996c. Appendix B.1 Particle size distribution data and sized emission factors for selected sources. *In* Compilation of Air Pollution Emission Factors. Vol. 1. Stationary Point and Area Sources. Publ. AP-42. U.S. Environmental Protection Agency, Washington, DC.
- Faulkner, W.B., L.B. Goodrich, V.S. Botlaguduru, S.C. Capareda, and C.B. Parnell. 2009. Particulate matter emission factors for almond harvest as a function of harvester speed. *J. Air Waste Manag. Assoc.* 59(8):943–949.
- Hinds, W.C. 1982. *Aerosol Technology; Properties, Behavior and Measurement of Airborne Particles*. 1st Ed. Wiley-Interscience, New York, NY.
- Hughs, S.E., and P.J. Wakelyn. 1997. Physical characteristics of cyclone particulate emissions. *Appl. Eng. Agric.* 13(4):531–535.
- Hughs, S.E., M.N. Gillum, and B.M. Armijo. 1982. Collecting particles from gin lint cleaner air exhausts. *Trans. ASAE*. 25(5):1435–1438.
- Hughs, S.E., P.J. Wakelyn, M.A. Rousselle, and E.P. Columbus. 1997. Chemical composition of cotton gin external emissions: proximate and elemental analysis. *Trans. ASAE*. 40(3):519–527.
- Lacey, R.E., J.S. Redwine, and C.B. Parnell, Jr. 2003. Particulate matter and ammonia emission factors for tunnel-ventilated broiler production houses in the Southern U.S. *Trans. ASABE*. 46(4):1203–1214.
- National Agricultural Statistics Service (NASS). 2001. Cotton Ginnings Annual Summary [Online]. USDA National Agricultural Statistics Service, Washington, DC. Available at <http://usda.mannlib.cornell.edu/usda/nass/CottGinnSu/2000s/2001/CottGinnSu-05-10-2001.pdf> (verified 20 May 2015).
- National Agricultural Statistics Service (NASS). 2012. Cotton Ginnings Annual Summary [Online]. USDA National Agricultural Statistics Service, Washington, DC. Available at <http://usda.mannlib.cornell.edu/usda/nass/CottGinnSu/2010s/2012/CottGinnSu-05-10-2012.pdf> (verified 20 May 2015).
- Sweeten, J.M., C.B. Parnell Jr., B.W. Shaw, and B.W. Auverman. 1998. Particle size distribution of cattle feedlot dust emission. *Trans. ASABE*. 41(5):1477–1481.
- Valco, T.D., H. Ashley, J.K. Green, D.S. Findley, T.L. Price, J.M. Fannin, and R.A. Isom. 2012. The cost of ginning cotton—2010 survey results. p. 616–619 *In* Proc. Beltwide Cotton Conference, Orlando, FL 3-6 Jan. 2012. Natl. Cotton Counc. Am., Cordova, TN.
- Valco, T.D., B. Collins, D.S. Findley, J.K. Green, L. Todd, R.A. Isom, and M.H. Wilcutt. 2003. The cost of ginning cotton—2001 survey results. p. 662–670 *In* Proc. Beltwide Cotton Conference, Nashville, TN 6-10 Jan. 2003. Natl. Cotton Counc. Am., Memphis, TN.
- Valco, T.D., J.K. Green, R.A. Isom, D.S. Findley, T.L. Price, and H. Ashley. 2009. The cost of ginning cotton—2007 survey results. p. 540–545 *In* Proc. Beltwide Cotton Conference, San Antonio, TX 5-8 Jan. 2009. Natl. Cotton Counc. Am., Cordova, TN.

- Valco, T.D., J.K. Green, T.L. Price, R.A. Isom, and D.S. Findley. 2006. Cost of ginning cotton—2004 survey results. p. 618–626 *In Proc. Beltwide Cotton Conference*, San Antonio, TX 3-6 Jan. 2006. Natl. Cotton Counc. Am., Memphis, TN.
- Wang-Li, L., Z. Cao, M. Buser, D. Whitelock, C.B. Parnell, and Y. Zhang. 2013. Techniques for measuring particle size distribution of particulate matter emitted from animal feeding operations. *J. Atmos. Environ.* 66(2013):25–32.
- Wakelyn, P.J., D.W. Thompson, B.M. Norman, C.B. Nevius, and D.S. Findley. 2005. Why cotton ginning is considered agriculture. Cotton Gin and Oil Mill Press. 106(8):5–9.
- Wesley, R., W. Mayfield, and O. McCaskill. 1972. An evaluation of the cyclone collector for cotton gins. Tech. Bull. No. 1439. USDA Agricultural Research Service, Beltsville, MD.
- Whitelock, D.P., M.D. Buser, J.C. Boykin, and G.A. Holt. 2014. Second stage seed-cotton cleaning system PM₁₀ emission factors and rates from cotton gins: Method 201A PM₁₀ sizing cyclones. *J. Cotton Sci.* 18(2):195–206.
- Whitelock, D.P., C.B. Armijo, M.D. Buser, and S.E. Hughs. 2009 Using cyclones effectively at cotton gins. *Appl. Eng. Ag.* 25(4):563–576.