

ENGINEERING AND GINNING

First Stage Lint Cleaning Systems Emission Factors and Rates for Cotton Gins: Method 201A PM₁₀ Sizing Cyclones

Michael D. Buser*, Derek P. Whitelock, J. Clif Boykin, and Gregory A. Holt

ABSTRACT

This report is part of a project to characterize cotton gin emissions from the standpoint of stack sampling. The impetus behind this project was the urgent need to collect cotton gin emissions data to address current regulatory issues. A key component of this study was focused on EPA emission factors for particulate matter with a particle diameter nominally less than or equal to 10 μm (PM₁₀). The 1996 EPA AP-42 emission factors were assigned quality ratings, from A (Excellent) to E (Poor), to assess the quality of the data being referenced. Emission factor quality ratings for cotton gins were extremely low. Also, some commonly used cotton gin systems were not represented or were combined with another system under a single emission factor in AP-42. No EPA AP-42 emission factors were published for 1st stage lint cleaning systems. The objective of this study was to collect PM₁₀ emission factor data for 1st stage lint cleaning systems at cotton gins located in regions across the cotton belt based on EPA-approved stack sampling methodology, Method 201A. The project plan included sampling seven cotton gins across the cotton belt. Key factors for selecting specific cotton gins included: 1) facility location, 2) production capacity, 3) processing systems and 4) abatement technologies. Four of the seven gins were equipped with 1st stage lint cleaning systems where the exhaust airstreams were not combined with 2nd stage lint cleaning systems. In terms of capacity, the four

gins were typical of the industry, averaging 28.1 bales/h during testing. Some test runs, included in the analyses, had cotton lint fibers that collected in the $\leq 10 \mu\text{m}$ samples. This larger lint material can affect the reported emissions data, but EPA Method 201A does not suggest methods to account for these anomalies. The 1st stage lint cleaning system average emission factors for PM₁₀ and total particulate were 0.041 kg/227-kg bale (0.091 lb/500-lb bale) and 0.066 kg/bale (0.146 lb/bale), respectively. System average PM₁₀ and total particulate emission factors were lower than those currently published in EPA AP-42 for 1st and 2nd stage lint cleaning systems combined. The 1st stage lint cleaning system PM₁₀ emission rate test averages ranged from 0.26 to 2.92 kg/h (0.58-6.44 lb/h). The ratio of 1st stage lint cleaning system PM₁₀ to total particulate was 62.3%.

The United States (U.S.) Environmental Protection Agency (EPA) emission factors were published in EPA's Compilation of Air Pollution Emission Factors, AP-42 (EPA, 1996b). These factors were assigned a rating from A (Excellent) to E (Poor) that is used to assess the quality of the data being referenced. In the 1996 EPA AP-42, there are emission factors for particulate matter with a particle diameter less than or equal to a nominal 10- μm (PM₁₀) aerodynamic equivalent diameter listed for eleven common cotton gin systems. The EPA emission factor quality ratings for these data are extremely low. Cotton gin data received these low ratings because they were collected almost exclusively from a single geographical region (EPA, 1996a). The AP-42 data are limited in that some systems commonly used in cotton gins are not represented or are combined with another system under a single emission factor (e.g., 1st and 2nd stage lint cleaning systems are represented by lint cleaners). Cotton ginners' associations across the cotton belt, including the National, Texas, Southern, Southeastern, and California associations, agreed that there was an urgent need to collect additional cotton gin emissions data to address current regulatory issues. Working

M.D. Buser*, Oklahoma State University, Biosystems and Agricultural Engineering, 214 Agricultural Hall, Stillwater, OK 74078; D.P. Whitelock, USDA-ARS Southwestern Cotton Ginning Research Laboratory, 300 College Dr., P.O. Box 578, Mesilla Park, NM 88047; J.C. Boykin, USDA-ARS Cotton Ginning Research Unit, 111 Experiment Station Road, P.O. Box 256, Stoneville, MS 38776; G.A. Holt, USDA-ARS Cotton Production and Processing Research Unit, 1604 E. FM 1294, Lubbock, TX 79403

*Corresponding author: buser@okstate.edu

with cotton ginning associations across the country and state and federal regulatory agencies, Oklahoma State University and the United States Department of Agriculture (USDA-Agricultural Research Service (ARS) researchers developed a proposal and sampling plan that was initiated in 2008 to address this need for additional data. This report is part of a series that details cotton gin emissions measured by stack sampling. Each manuscript in the series addresses a specific cotton ginning system. The systems covered in the series include: unloading, 1st stage seed-cotton cleaning, 2nd stage seed-cotton cleaning, 3rd stage seed-cotton cleaning, overflow, 1st stage lint cleaning, 2nd stage lint cleaning, combined lint cleaning, cyclone robber, 1st stage mote, 2nd stage mote, combined mote, mote cyclone robber, mote cleaner, mote trash, battery condenser and master trash. This report focuses on PM₁₀ emissions from 1st stage lint cleaning systems.

There were no 1996 EPA AP-42 emission factors for 1st stage lint cleaning systems (EPA, 1996b). First stage lint cleaning systems would be similar to lint cleaners listed in AP-42, but the AP-42 factor represents 1st and 2nd stage lint cleaning systems combined. The AP-42 average PM₁₀ emission factor for lint cleaners with high-efficiency cyclones (combined 1st and 2nd stage lint cleaning systems) was 0.11 kg (0.24 lb) per 217-kg (480-lb) equivalent bale with a range of 0.020 to 0.42 kg (0.043-0.93 lb) per bale (EPA, 1996a, 1996b). This average and range was based on six tests conducted in one geographical location and the EPA emission factor quality rating was D, which is the second lowest possible rating (EPA, 1996a). The AP-42 average total particulate emission factor for lint cleaners with high-efficiency cyclones was 0.26 kg (0.58 lb) per bale with a range of 0.041 to 1.0 kg (0.090-2.3 lb) per bale. This average and range was based on six tests conducted in one geographical location. The EPA total particulate emission factor quality rating was also D.

Seed cotton is a perishable commodity that has no real value until the fiber and seed are separated (Wakelyn et al., 2005). Cotton must be processed or ginned at the cotton gin to separate the fiber and seed, producing 227-kg (500-lb) bales of marketable cotton fiber. Cotton ginning is considered an agricultural process and an extension of the harvest by several federal and state agencies (Wakelyn et al., 2005). Although the main function of the cotton gin is to remove the lint fiber from the seed, many other processes also occur during ginning, such as cleaning, drying, and

packaging the lint. Pneumatic conveying systems are the primary method of material handling in the cotton gin. As material reaches a processing point, the conveying air is separated and emitted outside the gin through a pollution control device. The amount of dust emitted by a system varies with the process and the condition of the material in the process.

Cotton ginning is a seasonal industry with the ginning season lasting from 75 to 120 days, depending on the size and condition of the crop. Although the trend for U.S. cotton production remained generally flat at about 17 million bales per year during the last 20 years, production from one year to the next often varied greatly for various reasons, including climate and market pressure (Fig. 1). The number of active gins in the U.S. has not remained constant, but has steadily declined to fewer than 700 in 2011. Consequently, the average volume of cotton handled by each gin has risen and gin capacity has increased to an average of about 25 bales per hour across the U.S. cotton belt (Valco et al., 2003, 2006, 2009, 2012).

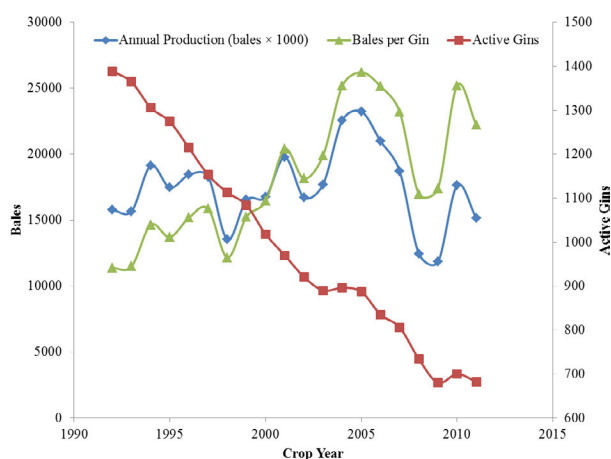

Figure 1. Annual U.S. cotton production, active U.S. gins, and average ginning volume (bales per gin) (NASS, 1993-2012).

Typical cotton gin processing systems include: unloading system, dryers, seed-cotton cleaners, gin stands, overflow collector, lint cleaners, battery condenser, bale packaging system, and trash handling systems (Fig. 2); however, the number and type of machines and processes can vary. Each of these systems serves a unique function with the ultimate goal of ginning the cotton to produce a marketable product. Raw seed cotton harvested from the field is compacted into large units called “modules” for delivery to the gin. The unloading system removes seed cotton either mechanically or pneumatically from the module feed system and conveys the seed cotton to the seed-cotton cleaning systems. Seed-cotton cleaning systems as-

sist with drying the seed cotton and remove foreign matter prior to ginning. Ginning systems also remove foreign matter and separate the cotton fiber from seed. Lint cleaning systems further clean the cotton lint after ginning. The battery condenser and packaging systems combine lint from the lint cleaning systems and compress the lint into dense bales for efficient transport. Cotton gin systems produce some type of by-products or trash, such as rocks, soil, sticks, hulls, leaf material, and short or tangled immature fiber (motes), as a result of processing the seed cotton or lint. These streams of by-products must be removed from the machinery and handled by trash collection systems. These trash systems typically further process the by-products (e.g., mote cleaners) and/or consolidate the trash from the gin systems into a hopper or pile for subsequent removal.

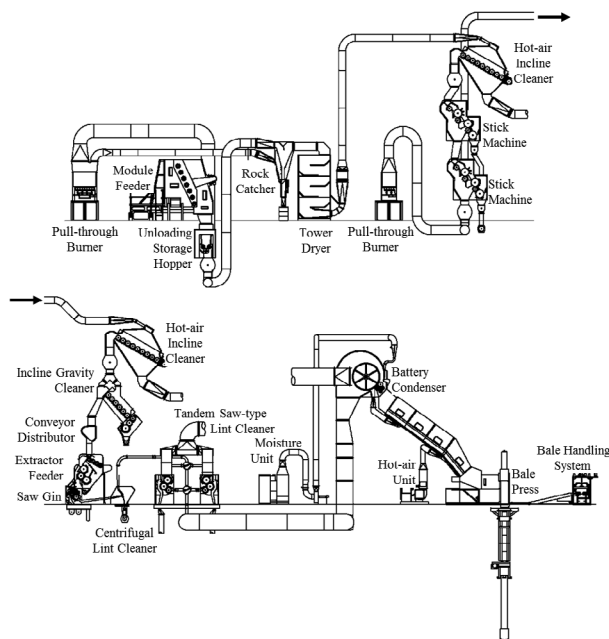

Figure 2. Typical modern cotton gin layout (Courtesy Lummus Corporation, Savannah, GA).

Cotton lint is cleaned in the lint cleaning systems (Fig. 3). In the typical 1st and 2nd stage lint cleaning system, lint is pneumatically conveyed from the gin stands, through a centrifugal lint cleaner, to the 1st stage lint cleaners (cotton gins typically split the pre-cleaned seed cotton among multiple, parallel gin stand/lint cleaning lines that are recombined at packaging) for further foreign matter removal. The lint is removed from the airstream with a rotating, screened separator drum and directed into the lint cleaner feed works. Lint cleaners remove fine trash, seed, and some lint. The material removed by lint cleaners is referred to as “motes”. Lint is directed

from the lint cleaner to either a subsequent stage of lint cleaning or into the bale packaging system. A 2nd stage of lint cleaning is sometimes used and is essentially identical to the 1st stage. The airstream from the lint cleaner screened separators continues through a centrifugal fan to one or two particulate abatement cyclones. Some lint cleaning systems utilize a vane-axial fan, but these systems typically do not have cyclones and exhaust directly to ambient air. The pneumatic systems of the two lint-cleaning stages may share a fan and abatement device or may operate independently, as is the case with 1st stage lint cleaning systems. The material handled by the lint cleaner cyclones typically includes small trash and particulate, and lint fibers (Fig. 4).

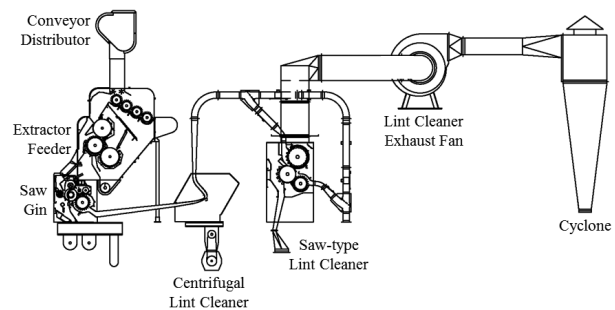

Figure 3. Typical cotton gin 1st stage lint cleaning system layout (Courtesy Lummus Corporation, Savannah, GA).



Figure 4. Photograph of typical trash captured by the 1st stage lint cleaning system cyclones.

Cyclones are the most common particulate matter abatement devices used at cotton gins. Standard cyclone designs used at cotton ginning facilities are the 2D2D and 1D3D (Whitelock et al., 2009). The first D in the designation indicates the length of the cyclone barrel relative to the cyclone barrel diameter and the second D indicates the length of the cyclone cone relative to the cyclone barrel diameter. A standard 2D2D cyclone (Fig. 5) has an inlet height of D/2

and width of $D/4$ and design inlet velocity of 15.2 ± 2 m/s (3000 ± 400 fpm). The standard 1D3D cyclone (Fig. 5) has the same inlet dimensions as the 2D2D or may have the original 1D3D inlet with height of D and width $D/8$. Also, it has a design inlet velocity of 16.3 ± 2 m/s (3200 ± 400 fpm).

The objective of this study was to collect PM_{10} emission factor data for 1st stage lint cleaning systems with cyclones for emissions control at cotton gins located in regions across the cotton belt based on EPA-approved stack sampling methodologies.

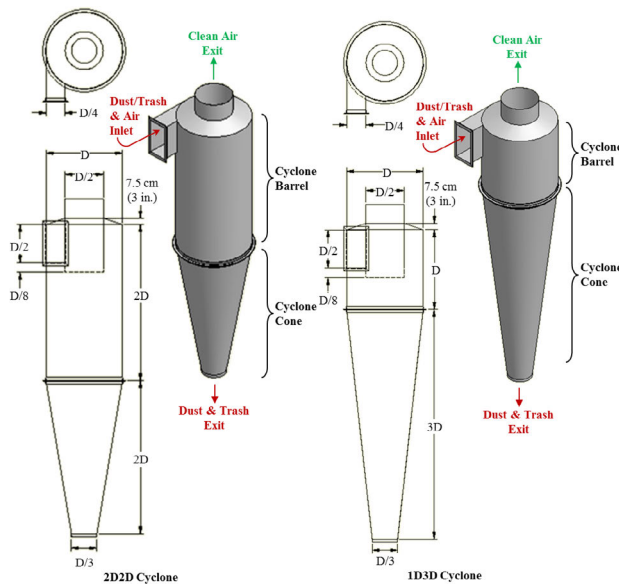

Figure 5. 2D2D and 1D3D cyclone schematics.

METHODS

Two advisory groups were established for this project. The industry group consisted of cotton ginning industry leaders and university and government researchers. The air quality group included members from state and federal regulatory agencies and university and government researchers. These groups were formed to aid in project planning, gin selection, data analysis, and reporting. The project plan was described in detail by Buser et al. (2012).

Seven cotton gins were sampled across the cotton belt. Key factors for selecting specific cotton gins included: 1) facility location, 2) production capacity, 3) processing systems and 4) abatement technologies. Operating permits, site plans, and aerial photographs were reviewed to evaluate potential sites. On-site visits were conducted on all candidate gins to evaluate the process systems and gather information including system condition, layout, capacities, and standard

operation. Using this information, several gins from each selected geographical region were selected and prioritized based on industry advisory group discussions. Final gin selection from the prioritized list was influenced by crop limitations and adverse weather events in the region.

Based on air quality advisory group consensus, EPA Method 201A was used to sample the 1st stage lint cleaning system at each gin. Method 201A was revised in 2010 to incorporate options for $PM_{2.5}$ (particulate matter with particle diameter less than or equal to a nominal 2.5- μ m aerodynamic equivalent diameter) sampling (CFR, 2010); these revisions did not affect the PM_{10} stack sampling methodology used in this project. Method 201A is a constant sampling rate procedure. For the PM_{10} sampling methodology, the particulate-laden stack gas was withdrawn isokinetically (the velocity of the gas entering the sampler was equal to the velocity of the gas in the stack) through a PM_{10} sizing cyclone and then collected on an in-stack filter (Fig. 6). The methods for retrieving the filter and conducting acetone washes of the sizing cyclone are described in detail in Method 201A (CFR, 2010). The mass of each size fraction was determined by gravimetric analysis and included: $> 10 \mu$ m (PM_{10} sizing cyclone catch acetone wash) and $\leq 10 \mu$ m (PM_{10} sizing cyclone exit acetone wash and filter). The PM_{10} mass was determined by adding the mass of particulates captured on the filter and the $\leq 10 \mu$ m wash. Total particulate was determined by adding the PM_{10} mass and the mass of the $> 10 \mu$ m wash.

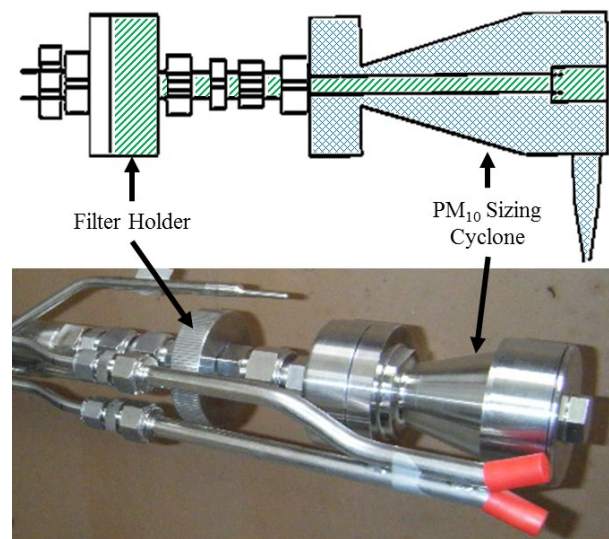

Figure 6. EPA Method 201A PM_{10} sizing cyclone and in-stack filter holder schematic (CFR, 2010) and photograph (// $\leq 10 \mu$ m, // $> 10 \mu$ m).

Figure 7 shows the performance curves for the Method 201A sizing cyclones. To measure PM₁₀, the method requires selecting a gas sampling nozzle to achieve a sampling rate that produces a cut size between 9.0 and 11.0 μm at the stack gas temperature. For this study, Method 201A was specifically used to collect filterable PM₁₀ emissions (solid particles emitted by a source at the stack and captured in the ≤ 10 μm wash and on the filter [CFR, 2010]).

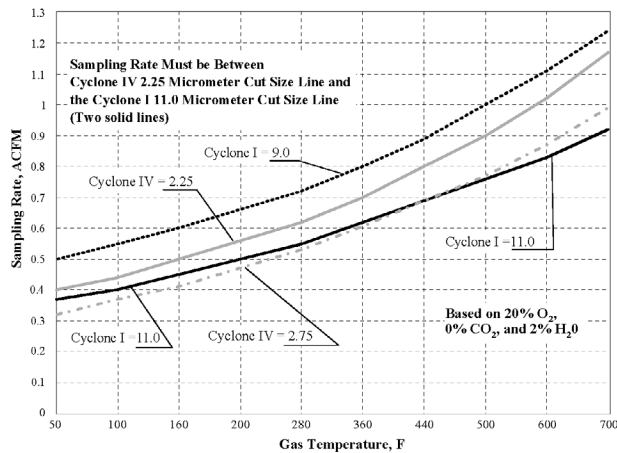

Figure 7. Acceptable sampling rate for sizing cyclones (CFR, 2010) Cyclone I = PM₁₀ sizing cyclone (Gas temperatures for the 1st stage lint cleaning systems ranged from 22 to 39°C [71-102°F]).

Only one stack from each 1st stage lint cleaning system was tested. For systems with multiple stacks, it was assumed that emissions from each stack of the system were equivalent and the total emissions were calculated by multiplying the measured emission rates by the total number of cyclones used to control the process tested (EPA, 1996a). To obtain reliable results, the same technician from the same certified stack sampling company (Reliable Emissions Measurements, Auberry, CA), trained and experienced in stack sampling cotton gins, conducted the tests at all seven cotton gins.

All stack sampling equipment, including the sizing cyclone, was purchased from Apex Instruments (Fuquay-Varina, NC) and met specifications of Method 201A. The sampling media were 47 μm Zefluor filters (Pall Corporation, Port Washington, NY) and the sample recovery and analytical reagent was American Chemical Society certified acetone (A18-4, Fisher Chemical, Pittsburgh, PA – assay ≥ 99.5%). Filters and wash tubs and lids were pre-labeled, pre-weighed, and stored in sealed containers at the USDA-ARS Air Quality Lab (AQL) in Lubbock, TX, and then transported to each test site.

Prior to testing, the certified stack testing technician calibrated and checked all sampling equipment according to EPA Method 201A.

Each cyclone selected for testing was fitted with a cyclone stack extension that incorporated two sampling ports (90° apart) and airflow straightening vanes to eliminate the cyclonic flow of the air exiting the cyclone (Fig. 8). The extensions were designed to meet EPA criteria (EPA, 1989) with an overall length of 3 m (10 ft) and sampling ports 1.2-m (48-in) downstream from the straightening vanes and 0.9-m (36-in.) upstream from the extension exit.

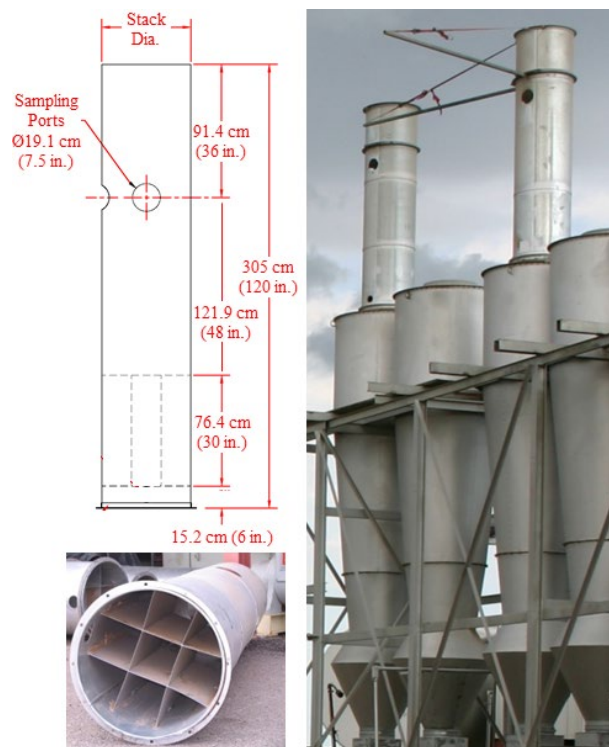

Figure 8. Schematic and photographs of stack extensions with sampling ports and straightening vanes (rail attached to extension above sampling port, at right, supports sampling probe during testing traverse).

The tests were conducted by the certified stack-sampling technician in an enclosed sampling trailer at the base of the cyclone bank (Fig. 9). Sample retrieval, including filters and sampler head acetone washes, was conducted according to Method 201A. After retrieval, filters were sealed in individual Petri dishes and acetone washes were dried on-site in a conduction oven at 49°C (120°F) and then sealed with pre-weighed lids and placed in individual plastic bags for transport to the AQL in Lubbock, TX for gravimetric analyses. During testing, bale data (ID number, weight, and date/time of bale pressing) were either manually recorded by the bale press operator

or captured electronically by the gin’s computer system for use in calculating emission factors in terms of kg/227-kg bale (lb/500-lb bale). Emission factors and rates were calculated in accordance with Method 201A and ASAE Standard S582 (ASABE, 2005).

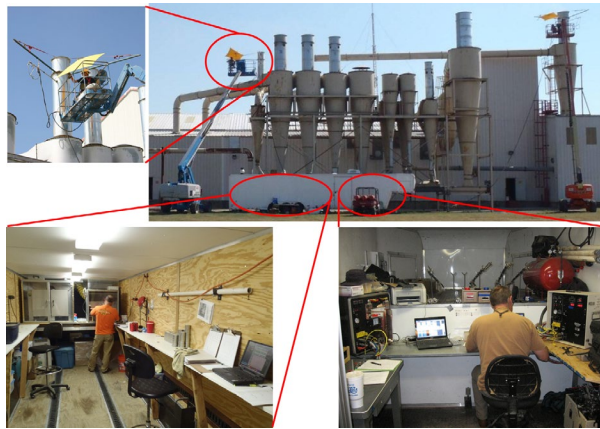

Figure 9. Clockwise from top right: cotton gin stack sampling with air quality lab trailer and technicians on lifts; certified stack sampling technician in the trailer control room conducting tests; sample recovery in trailer clean room; technician operating the probe at stack level.

All laboratory analyses were conducted at the AQL. All filters were conditioned in an environmental chamber ($21 \pm 2^\circ\text{C}$ [$70 \pm 3.6^\circ\text{F}$]; $35 \pm 5\%$ RH) for 48 h prior to gravimetric analyses. Filters were weighed in the environmental chamber on a Mettler MX-5 microbalance (Mettler-Toledo Inc., Columbus, OH – 1 μg readability and 0.9 μg repeatability) after being passed through an anti-static device. The MX-5 microbalance was leveled on a marble table and housed inside an acrylic box to minimize the effects of air currents and vibrations. To reduce recording errors, weights were electronically transferred from the microbalance directly to a spreadsheet. Technicians wore latex gloves and a particulate respirator mask to avoid contamination. AQL procedures required that each sample be weighed three times. If the standard deviation of the weights for a given sample exceeded 10 μg , the sample was reweighed. Gravimetric procedures for the acetone wash tubs were the same as those used for filters.

In addition to gravimetric analyses, each sample was visually inspected for unusual characteristics, such as cotton lint content or extraneous material. Digital pictures were taken of all filters and washes for documentation purposes prior to further analyses. After the laboratory analyses were completed all stack sampling, cotton gin production, and laboratory data were merged.

Four of the seven gins were equipped with 1st stage lint cleaning systems that were not combined with 2nd stage lint cleaning systems. The 1st stage lint cleaning systems sampled were typical for the industry. Gins A, B, and F had similar systems (Fig. 10). For these systems, the cotton lint was pneumatically conveyed from the gin stand, through a centrifugal lint cleaner where some larger trash was ejected. The air/material then proceeded to the 1st lint cleaner. At the lint cleaner, the lint was separated from the conveying air by a screened separator and fed into the lint cleaner. The airstream then passed through a fan and exhausted through one or more cyclones. The 1st stage lint cleaning systems at gin C were similar, except there were no centrifugal lint cleaners between the gin stands and 1st lint cleaners (Fig. 11).

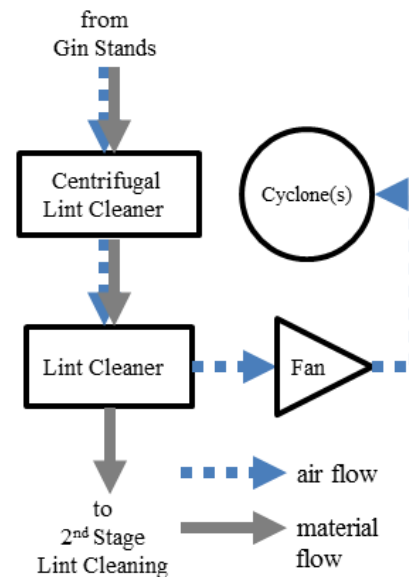

Figure 10. Schematic of 1st stage lint cleaning system with centrifugal lint cleaner (gins A, B, and F).

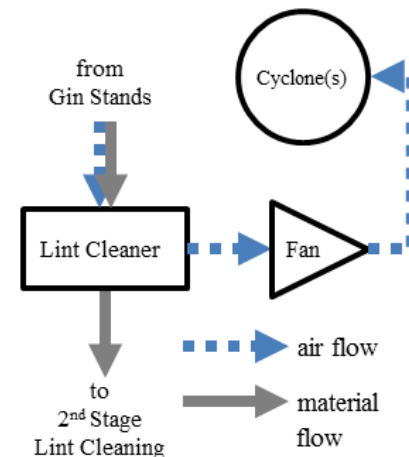

Figure 11. Schematic of 1st stage lint cleaning system without centrifugal lint cleaner (gins C).

All 1st stage lint cleaning systems sampled utilized 1D3D cyclones to control emissions (Fig. 5), but there were some cyclone design variations among the gins (Table 1 and Fig. 12). Gin C split the system exhaust flow between two cyclones in a dual configuration (side-by-side as opposed to one-behind-another). The system airstream for gins A, B, and F was exhausted through a single cyclone. Inlets on all the 1st stage lint cleaning cyclones were 2D2D type, except gin C that had 1D3D inlets with the duct in line with midpoint between the top and bottom of the inlet. Expansion chambers were present on the cones of the 1st stage lint cleaning system cyclones at gins A and B, while gins C and F had standard cones. The cyclones tested at gins C and F had cyclone robber systems pulling airflow from their trash exits. This configuration helps remove lint and other trash from the cyclone that could otherwise circulate near the trash exit at the bottom of the cone for a period of time before dropping out. All of the cyclone configurations outlined above, if properly designed and maintained, are recommended for controlling cotton gin emissions (Whitelock et al., 2009).

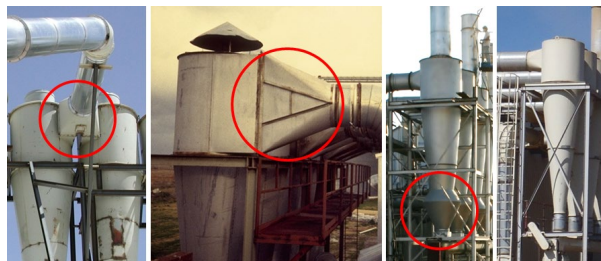

Figure 12. Cyclone design variations for the tested systems (left to right): dual configuration that splits flow between identical 1D3D cyclones with 2D2D inlets; 1D3D cyclone with a center-line 1D3D inlet; 1D3D cyclone with 2D2D inlet and expansion chamber on the cone; 1D3D cyclone with 2D2D inlet and standard cone.

RESULTS

Table 2 shows the test parameters for each Method 201A test run for the 1st stage lint cleaning systems sampled at the four gins. The system average ginning rate was 28.1 bales/h and the test average ginning rates at each gin ranged from 22.1 to 39.9 bales/h (based on 227-kg [500-lb] equivalent bales). The capacity of gins sampled was representative of the industry, approximately 25 bales/h. The 1D3D cyclones were all operated with inlet velocities within design criteria, 16.3 ± 2 m/s (3200 ± 400 fpm), except the test runs at gin C and run three at gin A that were outside the design range due to limitations in available system adjustments.

There are criteria specified in EPA Method 201A for test runs to be valid for PM₁₀ or total particulate measurements (CFR, 2010). Isokinetic sampling and PM₁₀ aerodynamic cut size must fall within EPA defined ranges ($100 \pm 20\%$ and 10.0 ± 1.0 μm, respectively) for valid PM₁₀ test runs. All tests met both criteria (Table 2). To use the method to also obtain total filterable particulate, sampling must be within 90 to 110% of isokinetic flow. All tests met this criterion. Sampling rates ranged from 12.4 to 14.2 standard l/min (0.437-0.502 standard ft³/min). The stack gas temperatures ranged from 22 to 39°C (71-102°F).

PM₁₀ emissions data (ginning and emission rates and corresponding emission factors) for the 1st stage lint cleaning systems are shown in Table 3. The system average PM₁₀ emission factor was 0.041 kg/bale (0.091 lb/bale). The test average emission factors ranged from 0.011 to 0.073 kg (0.024-0.161 lb) per bale and emission rates ranged from 0.26 to 2.92 kg/h (0.58-6.44 lb/h). Total particulate emissions data (ginning

Table 1. Abatement device configuration^z for 1st stage lint cleaning systems tested.

Gin	Cyclone Type	Inlet Design ^y	Systems per Gin	Cyclones per Gin	Configuration	Cone Design ^y	Trash Exits to ^x
A	1D3D	2D2D	3	3	single	expansion chamber	auger
B	1D3D	2D2D	4	4	single	expansion chamber	auger
C	1D3D	center-line 1D3D	2	4	dual	standard	robber
F	1D3D	2D2D	4	4	single	standard	robber

^z Figures 5 and 12

^y Center-line 1D3D inlet has duct in line with midpoint between the top and bottom of the inlet

^x Systems to remove material from cyclone trash exits: auger = enclosed, screw-type conveyor, robber = pneumatic suction system

and emission rates and corresponding emission factors) for the 1st stage lint cleaning systems are shown in Table 4. The system average total particulate emission factor was 0.066 kg/bale (0.146 lb/bale). The test average emission factors ranged from 0.026 to 0.108 kg (0.058-0.238 lb) per bale. The test average total particulate emission rates ranged from 0.64 to 4.32 kg/h (1.4-9.53 lb/h). The ratio of PM₁₀ to total particulate was 62.3% (ratios calculated using tables 3 and 4 may vary slightly from those listed due to rounding).

The average 1st stage lint cleaning system total particulate emission factor for this project was about 25% of the EPA AP-42 published value for the lint cleaners with high-efficiency cyclones (EPA, 1996a, 1996b), which is an equivalent system to combined 1st and 2nd stage lint cleaning systems. The range of test average total particulate emission factors determined for this project and the range of AP-42 emission factor data overlapped. The average 1st stage lint cleaning system

PM₁₀ emission factor for this project was 38% of the EPA AP-42 published value for the lint cleaners with high-efficiency cyclones. The test average PM₁₀ emission factor range also overlapped with AP-42 emission factor data range.

Figure 13 shows an example of samples recovered from a typical 1st stage lint cleaning system test run. Often, there were cotton lint fibers, which have cross-sectional diameters much greater than 10 μm, in the cotton gin cyclone exhausts. Therefore, it was not unusual to find lint fiber in the > 10 μm wash from Method 201A. However, in the samples shown in Figure 14, lint fibers passed through the PM₁₀ cyclone and collected on the filter. This type of material carryover can bias the gravimetric measurements and affect reported PM₁₀ emission data. EPA Method 201A does not suggest methods to account for these anomalies. Thus, no effort was made to adjust the data reported in this manuscript to account for these issues.

SUMMARY

Table 2. Cotton gin production data and stack sampling performance metrics for the 1st stage lint cleaning systems.

Gin	TestRun	Ginning Rate, bales/h ^z	Cyclone Inlet Velocity,		Isokinetic Sampling, %	Aerodynamic Cut Size D ₅₀ , PM ₁₀ μm	Sampling Rate ^y		Stack Temperature	
			m/s	fpm			slpm	scfm	°C	°F
A	1	23.3	14.7	2892	105	9.9	13.2	0.467	22	71
	2	22.8	14.4	2837	102	10.1	13.0	0.460	25	76
	3	20.0	14.1	2770	108	9.9	13.4	0.474	25	76
	Test Average	22.1	14.4	2833						
B	1	24.6	16.6	3262	103	10.3	12.6	0.445	38	100
	2	27.0	16.7	3286	105	10.2	12.9	0.455	39	102
	3	26.4	16.3	3218	108	10.1	13.0	0.458	38	100
	Test Average	26.0	16.5	3255						
C	1	23.8	11.7	2300	105	10.2	12.5	0.442	31	88
	2	25.4	11.6	2291	104	10.3	12.4	0.437	32	90
	3	23.8	12.9	2541	95	10.2	12.6	0.443	33	91
	Test Average	24.3	12.1	2377						
F	1	36.7	17.4	3419	95	10.3	12.8	0.452	36	97
	2	41.2	17.1	3357	108	9.6	14.2	0.502	38	100
	3	41.8	17.1	3364	102	10.0	13.5	0.475	38	101
	Test Average	39.9	17.2	3380						
System Average		28.1	15.0	2961						

^z 227 kg (500 lb) equivalent bales

^y slpm = standard l/min, scfm = standard ft³/min

Table 3. PM₁₀ emissions data for the 1st stage lint cleaning systems.

Gin	Test Run	Emission Rate,		Emission Factor,	
		kg/h	lb/h	kg/bale ^z	lb/bale ^z
A	1	1.15	2.54	0.049	0.109
	2	0.38	0.83	0.017	0.036
	3	1.36	3.00	0.068	0.150
Test Average (n=3)		0.96	2.12	0.045	0.098
B	1	1.02	2.26	0.042	0.092
	2	1.10	2.42	0.041	0.089
	3	0.71	1.56	0.027	0.059
Test Average (n=3)		0.94	2.08	0.036	0.080
C	1	0.23	0.52	0.010	0.022
	2	0.27	0.59	0.010	0.023
	3	0.29	0.64	0.012	0.027
Test Average (n=3)		0.26	0.58	0.011	0.024
F	1	2.50	5.52	0.068	0.150
	2	3.01	6.63	0.073	0.161
	3	3.25	7.17	0.078	0.172
Test Average (n=3)		2.92	6.44	0.073	0.161
System Average (n=4)				0.041	0.091

^z 227 kg (500 lb) equivalent bales

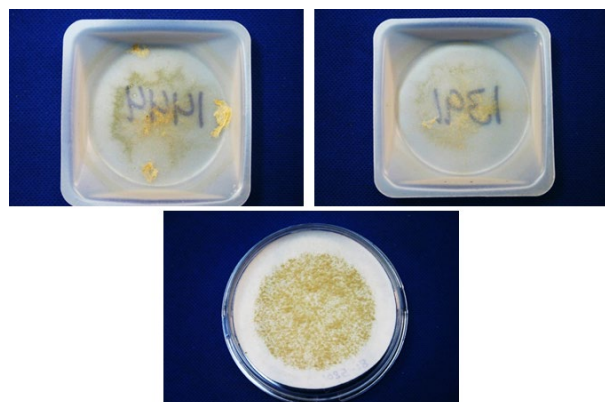

Figure 13. Typical EPA Method 201A filter and sampler head acetone washes from the 1st stage lint cleaning system. Clockwise from top left: > 10 µm wash, ≤ 10 µm wash, and filter.

Table 4. Total particulate emissions data for the 1st stage lint cleaning systems.

Gin	Test Run	Emission Rate,		Emission Factor,	
		kg/h	lb/h	kg/bale ^z	lb/bale ^z
A	1	1.83	4.04	0.079	0.173
	2	1.01	2.23	0.044	0.098
	3	1.94	4.28	0.097	0.214
Test Average (n=3)		1.60	3.52	0.073	0.162
B	1	1.69	3.72	0.069	0.151
	2	1.67	3.67	0.062	0.136
	3	1.09	2.40	0.041	0.091
Test Average (n=3)		1.48	3.26	0.057	0.126
C	1	0.58	1.27	0.024	0.053
	2	0.60	1.32	0.024	0.052
	3	0.74	1.63	0.031	0.068
Test Average (n=3)		0.64	1.41	0.026	0.058
F	1	3.54	7.80	0.096	0.213
	2	4.04	8.91	0.098	0.216
	3	5.39	11.88	0.129	0.284
Test Average (n=3)		4.32	9.53	0.108	0.238
System Average (n=4)				0.066	0.146

^z 227 kg (500 lb) equivalent bales



Figure 14. EPA Method 201A filter and sampler head acetone washes from the 1st stage lint cleaning system with lint fiber on the filter (indicated by arrow). Clockwise from top left: > 10 µm wash, ≤ 10 µm wash, and filter.

Seven cotton gins across the U.S. cotton belt were sampled using EPA Method 201A to collect data to fill the data gap that exists for cotton gin emissions data and improve EPA AP-42 PM₁₀ emission factor quality ratings for cotton gins. Four of the seven gins were equipped with 1st stage lint cleaning systems where the exhaust airstreams were not combined with 2nd stage lint cleaning systems. The tested systems were similar in design and typical of the ginning industry. All the systems were equipped with 1D3D cyclones for emissions control with some slight variations in inlet and cone design. In terms of capacity, the four gins were typical of the industry, averaging 28.1 bales/h during testing. Some test runs, included in the analyses, had cotton lint fibers that collected in the $\leq 10 \mu\text{m}$ samples. This larger lint material can affect the reported emissions data, but EPA Method 201A does not suggest methods to account for these anomalies. The 1st stage lint cleaning system average emission factors for PM₁₀ and total particulate were 0.041 kg/227-kg bale (0.091 lb/500-lb bale) and 0.066 kg/bale (0.146 lb/bale), respectively. System average PM₁₀ and total particulate emission factors were lower than those currently published in EPA AP-42 for 1st and 2nd stage lint cleaning systems combined. The gin test average PM₁₀ and total particulate emission rates ranged from 0.26 to 2.92 kg/h (0.58-6.44 lb/h) and 0.64 to 4.32 kg/h (1.41-9.53 lb/h), respectively. Based on the 1st stage lint cleaning system emission factors, the ratio of PM₁₀ to total particulate was 62.3%.

ACKNOWLEDGEMENT

The authors appreciate the cooperating gin managers and personnel who generously allowed and endured sampling at their gins. In addition, we thank California Cotton Ginners' and Growers' Association, Cotton Incorporated, San Joaquin Valleywide Air Pollution Study Agency, Southeastern Cotton Ginners' Association, Southern Cotton Ginners' Association, Texas Cotton Ginners' Association, Texas State Support Committee, and The Cotton Foundation for funding this project. The authors also thank the Cotton Gin Advisory Group and Air Quality Advisory Group for their involvement and participation in planning, execution, and data analyses for this project that is essential to developing quality data that will be used by industry, regulatory agencies, and the scientific community. The advisory groups included:

the funding agencies listed above, California Air Resources Board, Missouri Department of Natural Resources, National Cotton Council, National Cotton Ginners' Association, North Carolina Department of Environment and Natural Resources, San Joaquin Valley Air Pollution Control District, Texas A&M University, Texas Commission on Environmental Quality, USDA-NRCS National Air Quality and Atmospheric Change, and U.S. Environmental Protection Agency (national, Region 4 and 9).

DISCLAIMER

Mention of trade names or commercial products in this publication is solely for the purpose of providing specific information and does not imply recommendation or endorsement by the Oklahoma State University or U.S. Department of Agriculture. Oklahoma State University and USDA are equal opportunity providers and employers.

REFERENCES

- American Society of Agricultural and Biological Engineers (ASABE). 2005. Cotton Gins – Method of Utilizing Emission Factors in Determining Emission Parameters. ASAE S582 March 2005. American Society of Agricultural and Biological Engineers, St. Joseph, MI.
- Buser, M.D., D.P. Whitelock, J.C. Boykin, and G.A. Holt. 2012. Characterization of cotton gin particulate matter emissions—Project plan. *J. Cotton Sci.* 16:105–116.
- Code of Federal Regulations (CFR). 2010. Method 201A – Determination of PM₁₀ and PM_{2.5} emissions from stationary sources (Constant sampling rate procedure). 40 CFR 51 Appendix M. Available at <http://www.epa.gov/ttn/emc/promgate/m-201a.pdf> (verified 2 Jan. 2013).
- Environmental Protection Agency (EPA). 1989. Particulate sampling in cyclonic flow. U.S. Environmental Protection Agency, Washington, DC. Available online at <http://www.epa.gov/ttn/emc/guidlnd/gd-008.pdf> (verified 2 Jan. 2013).
- Environmental Protection Agency (EPA). 1996a. Emission factor documentation for AP-42, Section 9.7, Cotton Ginning, (EPA Contract No. 68-D2-0159; MRI Project No. 4603-01, Apr. 1996).
- Environmental Protection Agency (EPA). 1996b. Food and agricultural industries: Cotton gins. *In* Compilation of air pollution emission factors, Volume 1: Stationary point and area sources. Publ. AP-42. U.S. Environmental Protection Agency, Washington, DC.

- National Agricultural Statistics Service (NASS).1993-2012. Cotton Ginnings Annual Summary [Online]. USDA National Agricultural Statistics Service, Washington, DC. Available at <http://usda.mannlib.cornell.edu/MannUsda/viewDocumentInfo.do?documentID=1042> (verified 2 Jan. 2013).
- Valco, T.D., H. Ashley, J.K. Green, D.S. Findley, T.L. Price, J.M. Fannin, and R.A. Isom. 2012. The cost of ginning cotton – 2010 survey results. p. 616–619 *In Proc. Beltwide Cotton Conference.*, Orlando, FL 3-6 Jan. 2012. Natl. Cotton Counc. Am., Memphis, TN.
- Valco, T.D., B. Collins, D.S. Findley, J.K. Green, L. Todd, R.A. Isom, and M.H. Wilcutt. 2003. The cost of ginning cotton – 2001 survey results. p. 662–670 *In Proc. Beltwide Cotton Conference.*, Nashville, TN 6-10 Jan. 2003. Natl. Cotton Counc. Am., Memphis, TN.
- Valco, T.D., J.K. Green, R.A. Isom, D.S. Findley, T.L. Price, and H. Ashley. 2009. The cost of ginning cotton – 2007 survey results. p. 540–545 *In Proc. Beltwide Cotton Conference.*, San Antonio, TX 5-8 Jan. 2009. Natl. Cotton Counc. Am., Memphis, TN.
- Valco, T.D., J.K. Green, T.L. Price, R.A. Isom, and D.S. Findley. 2006. Cost of ginning cotton – 2004 survey results. p. 618–626 *In Proc. Beltwide Cotton Conference.*, San Antonio, TX 3-6 Jan. 2006. Natl. Cotton Counc. Am., Memphis, TN.
- Wakelyn, P.J., D.W. Thompson, B.M. Norman, C.B. Nevius, and D.S. Findley. 2005. Why Cotton Ginning is Considered Agriculture. *Cotton Gin and Oil Mill Press* 106(8): 5-9.
- Whitelock, D.P., C.B. Armijo, M.D. Buser, and S.E. Hughs. 2009 Using cyclones effectively at cotton gins. *Appl. Eng. Ag.* 25:563–576.