

ENGINEERING AND GINNING

Second Stage Lint Cleaning System PM_{2.5} Emission Factors and Rates for Cotton Gins: Method 201A Combination PM₁₀ and PM_{2.5} Sizing Cyclones

J. Clif Boykin, Michael D. Buser*, Derek P. Whitelock, and Gregory A. Holt

ABSTRACT

This report is part of a project to characterize cotton gin emissions from the standpoint of stack sampling. In 2006, EPA finalized a more stringent standard for particulate matter with nominal diameter less than or equal to 2.5 μm (PM_{2.5}). This created an urgent need to collect additional cotton gin emissions data to address current regulatory issues, because current EPA AP-42 cotton gin PM_{2.5} emission factors did not exist. The objective of this study was the development of PM_{2.5} emission factors for cotton gin 2nd stage lint cleaning systems based on the EPA-approved stack sampling methodology, Method 201A. The project plan included sampling seven cotton gins across the cotton belt. Key factors for selecting specific cotton gins included: 1) facility location (geographically diverse), 2) industry representative production capacity, 3) typical processing systems, and 4) equipped with properly designed and maintained 1D3D cyclones. Four of the seven gins were equipped with 2nd stage lint cleaning systems where the exhaust airstreams were not combined with 1st stage lint cleaning systems. In terms of capacity, the four gins were typical of the industry; averaging 27.3 bales/h during testing. Some test runs were excluded from the test averages because they failed to meet EPA Method 201A test criteria. Also, other test runs included in the analyses had cotton lint fibers that collected in the $\leq 10 \mu\text{m}$ and/or $\leq 2.5 \mu\text{m}$ samples. This larger lint material can impact the reported emissions data,

but EPA Method 201A does not suggest methods to account for these anomalies. Average measured 2nd stage lint cleaning system PM_{2.5} emission factor based on the four tests (nine total test runs) was 0.0051 kg/227-kg bale (0.011 lb/500-lb bale). The 2nd stage lint cleaning system average emission factors for PM₁₀ and total particulate were 0.022 kg/bale (0.048 lb/bale) and 0.033 kg/bale (0.074 lb/bale), respectively. The 2nd stage lint cleaning system PM_{2.5} emission rate from test averages ranged from 0.067 to 0.38 kg/h (0.15–0.83 lb/h). System average PM₁₀ and total particulate emission factors were lower than those currently published in EPA AP-42. The ratios of 2nd stage lint cleaning system PM_{2.5} to total particulate, PM_{2.5} to PM₁₀, and PM₁₀ to total particulate were 15.2, 23.1, and 65.7%, respectively.

In 2006, the U.S. Environmental Protection Agency (EPA) finalized a more stringent standard for particulate matter with a particle diameter less than or equal to a nominal 2.5- μm (PM_{2.5}) aerodynamic equivalent diameter (CFR, 2006). The cotton industry's primary concern with this standard was that there were no published cotton gin PM_{2.5} emissions data. Cotton ginners' associations across the cotton belt, including the National, Texas, Southern, Southeastern, and California associations, agreed that there was an urgent need to collect PM_{2.5} cotton gin emissions data to address the implementation of the PM_{2.5} standards. Working with cotton ginning associations across the country, state and federal regulatory agencies, Oklahoma State University, and USDA-Agricultural Research Service (ARS) researchers developed a proposal and sampling plan that was initiated in 2008 to address this need for additional data. This report is part of a series that cotton gin emissions measured by stack sampling. Each manuscript in the series addresses a specific cotton ginning system. The systems covered in the series include: unloading, 1st stage seed-cotton cleaning, 2nd stage seed-cotton cleaning, 3rd stage seed-cotton cleaning, overflow, 1st stage lint cleaning, 2nd stage lint cleaning, combined lint

J.C. Boykin, USDA-ARS Cotton Ginning Research Unit, 111 Experiment Station Road, P.O. Box 256, Stoneville, MS 38776; M.D. Buser*, Biosystems and Agricultural Engineering, Oklahoma State University, 214 Agricultural Hall, Stillwater, OK 74078; D.P. Whitelock, USDA-ARS Southwestern Cotton Ginning Research Laboratory, 300 E College Dr., P.O. Box 578, Mesilla Park, NM 88047; and G.A. Holt, USDA-ARS Cotton Production and Processing Research Unit, Rt. 3 Box 215, Lubbock, TX 79401

*Corresponding author: buser@okstate.edu

cleaning, cyclone robber, 1st stage mote, 2nd stage mote, combined mote, mote cyclone robber, mote cleaner, mote trash, battery condenser, and master trash. This report focuses on PM_{2.5} emissions from 2nd stage lint cleaning systems.

There are published PM₁₀ (particulate matter with a particle diameter less than or equal to a nominal 10- μ m aerodynamic equivalent diameter) and total particulate emission factors for cotton gins in EPA's Compilation of Air Pollution Emission Factors, AP-42 (EPA, 1996a, b); however, there are no PM_{2.5} emission factors. The AP-42 average PM₁₀ emission factor for lint cleaners with high-efficiency cyclones (combined 1st and 2nd stage lint cleaning systems) was 0.11 kg (0.24 lb) per 217-kg (480-lb) equivalent bale with a range of 0.020 to 0.42 kg (0.043-0.93 lb) per bale. The AP-42 average total particulate emission factor was 0.26 kg (0.58 lb) per bale with a range of 0.041 to 1.0 kg (0.090-2.3 lb) per bale. These PM₁₀ and total factors were each based on six tests and were assigned EPA emission factor quality ratings of D; the second lowest possible rating (EPA, 1996a).

Seed cotton is a perishable commodity that has no real value until the fiber and seed are separated (Wakelyn et al., 2005). Cotton must be processed or ginned at the cotton gin to separate the fiber and seed, producing 227-kg (500-lb) bales of marketable cotton fiber. Cotton ginning is considered an agricultural process and an extension of the harvest by several federal and state agencies (Wakelyn et al., 2005). Although the main function of the cotton gin is to remove the lint fiber from the seed, many other processes also occur during ginning, such as cleaning, drying, and packaging the lint. Pneumatic conveying systems are the primary method of material handling in the cotton gin. As material reaches a processing point, the conveying air is separated and emitted outside the gin through a pollution control device. The amount of dust emitted by a system varies with the process and the condition of the material in the process.

Cotton ginning is a seasonal industry with the ginning season lasting from 75 to 120 days, depending on the size and condition of the crop. Although the trend for U.S. cotton production remained generally flat at about 17 million bales per year during the last 20 years, production from one year to the next often varied greatly for various reasons, including climate and market pressure (Fig. 1). The number of active gins in the U.S. has not remained constant, steadily declining to less than 700 in 2011. Consequently, the average volume of cotton handled by

each gin has risen and gin capacity has increased to an average of approximately 25 bales per hour across the U.S. cotton belt (Valco et al., 2003, 2006, 2009, 2012).

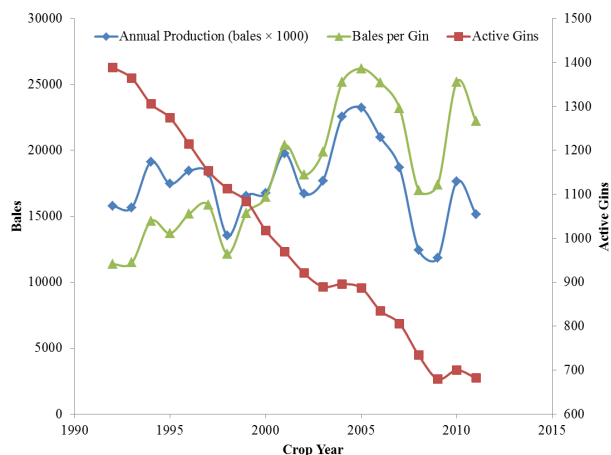

Figure 1. Annual U.S. cotton production, active U.S. gins, and average ginning volume (bales per gin) (NASS, 1993-2012).

Typical cotton gin processing systems include: unloading system, dryers, seed-cotton cleaners, gin stands, overflow collector, lint cleaners, battery condenser, bale packaging system, and trash handling systems (Fig. 2); however, the number and type of machines and processes can vary. Each of these systems serves a unique function with the ultimate goal of ginning the cotton to produce a marketable product. Raw seed cotton harvested from the field is compacted into large units called “modules” for delivery to the gin. The unloading system removes seed cotton either mechanically or pneumatically from the module feed system and conveys the seed cotton to the seed-cotton cleaning systems. Seed-cotton cleaning systems dry the seed cotton and remove foreign matter prior to ginning. Ginning systems also remove foreign matter and separate the cotton fiber from the seed. Lint cleaning systems further clean the cotton lint after ginning. The battery condenser and packaging systems combine lint from the lint cleaning systems and compress the lint into dense bales for efficient transport. Gin systems produce some type of by-products or trash, such as rocks, soil, sticks, hulls, leaf material, and short or tangled immature fiber (motes), as a result of processing the seed cotton or lint. These streams of by-products must be removed from the machinery and handled by trash collection systems. These trash systems typically further process the by-products (e.g., mote cleaners) and/or consolidate the trash from the gin systems into a hopper or pile for subsequent removal.

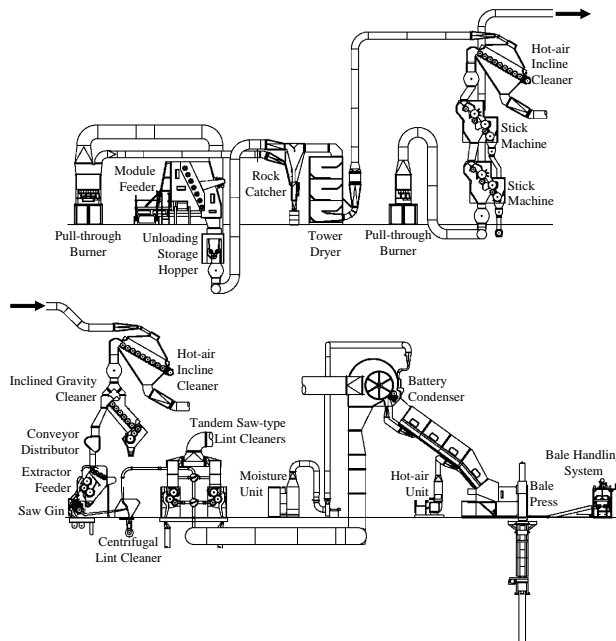

Figure 2. Typical modern cotton gin layout (Courtesy Lum-mus Corp., Savannah, GA).

Cotton lint is cleaned in the lint cleaning systems (Fig. 3). In the typical 1st and 2nd stage lint cleaning system, cotton fiber or lint is pneumatically conveyed from the gin stands, through a centrifugal lint cleaner, to the 1st stage lint cleaners (cotton gins typically split the pre-cleaned seed-cotton among multiple, parallel gin stand/lint cleaning lines that are recombined at packaging) for further foreign matter removal. The lint is removed from the airstream with a rotating, screened separator drum and directed into the lint cleaner feed works. Lint cleaners remove fine trash, seed, and some lint. The material removed by lint cleaners is referred to as “motes”. Lint is directed from the lint cleaner to either a subsequent stage of lint cleaning or into the bale packaging system. A 2nd stage of lint cleaning is sometimes used and is essentially identical to the 1st stage. The airstream from the lint cleaner screened separator continues through a centrifugal fan to one or two particulate abatement cyclones. Some lint cleaning systems utilize a vane-axial fan, but these systems typically do not have cyclones and exhaust directly to ambient air. The pneumatic systems of the two lint cleaning stages might share a fan and abatement device or might operate independently, as is the case with 2nd stage lint cleaning systems. The material handled by the lint cleaner cyclones typically includes small trash and particulate, and lint fibers (Fig. 4).

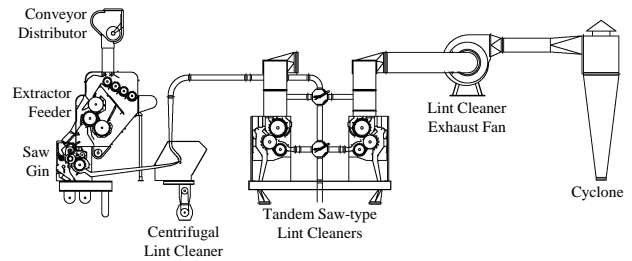

Figure 3. Typical cotton gin 2nd stage lint cleaning system layout (Courtesy Lummus Corp., Savannah, GA).



Figure 4. Photograph of typical trash captured by the 2nd stage lint cleaning system cyclones.

Cyclones are the most common particulate matter abatement devices used at cotton gins. Standard cyclone designs used at cotton ginning facilities are the 2D2D and 1D3D (Whitelock et al., 2009). The first D in the designation indicates the length of the cyclone barrel relative to the cyclone barrel diameter and the second D indicates the length of the cyclone cone relative to the cyclone barrel diameter. A standard 2D2D cyclone (Fig. 5) has an inlet height of D/2 and width of D/4 and design inlet velocity of 15.2 ± 2 m/s (3000 ± 400 fpm). The standard 1D3D cyclone (Fig. 5) has the same inlet dimensions as the 2D2D or might have the original 1D3D inlet with height of D and width D/8. Also, it has a design inlet velocity of 16.3 ± 2 m/s (3200 ± 400 fpm).

The objective of this study was the development of PM_{2.5} emission factors for cotton gin 2nd stage lint cleaning systems with cyclones for emissions control based on EPA-approved stack sampling methodologies.

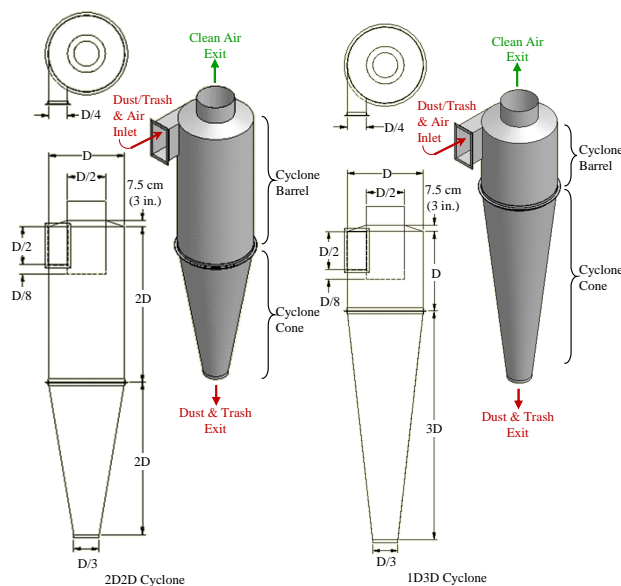

Figure 5. 2D2D and 1D3D cyclone schematics.

METHODS

Two advisory groups were established for this project. The industry group consisted of cotton ginning industry leaders and university and government researchers. The air quality group included members from state and federal regulatory agencies and university and government researchers. Both groups were formed to aid in project planning, gin selection, data analyses, and reporting. The project plan was described in detail by Buser et al. (2012).

Seven cotton gins were sampled across the cotton belt. Key factors for selecting specific cotton gins included: 1) facility location (geographically diverse), 2) industry representative production capacity, 3) typical processing systems, and 4) equipped with properly designed and maintained 1D3D cyclones. Operating permits, site plans, and aerial photographs were reviewed to evaluate potential sites. On-site visits were conducted on all candidate gins to evaluate the process systems and gather information including system condition, layout, capacities, and standard operation. Using this information, several gins from each selected geographical region were selected and prioritized based on industry advisory group discussions. Final gin selection from the prioritized list was influenced by crop limitations and adverse weather events in the region.

Based on air quality advisory group consensus, EPA Other Test Method 27 (OTM27) was used to sample the 2nd stage lint cleaning system at each

gin. When testing for this project began in 2008, OTM27 was the EPA method for determination of PM₁₀ and PM_{2.5} from stationary sources. In December 2010, OTM27 was replaced with a revised and finalized Method 201A (CFR, 2010). The revised Method 201A was a successor to OTM27. The two methods were similar to the point that EPA stated in an answer to a frequently asked question for Method 201A (EPA, 2010) that “If the source was using OTM 27 (and 28) for measuring either PM₁₀ or PM_{2.5} then using the revised reference methods Method 201A (and 202) should not be a concern and should give equivalent results.” Accordingly, OTM27 is no longer an EPA method that can be cited, and the revised Method 201A will be cited in this manuscript. Using Method 201A to sample PM_{2.5}, the particulate-laden stack gas was withdrawn isokinetically (the velocity of the gas entering the sampler was equal to the velocity of the gas in the stack) through a PM₁₀ sizing cyclone and a PM_{2.5} sizing cyclone, and then collected on an in-stack filter (Fig. 6). The methods for retrieving the filter and conducting acetone washes of the sizing cyclones are described in detail in Method 201A (CFR, 2010). The mass of each size fraction was determined by gravimetric analysis and included: > 10 μm (PM₁₀ sizing cyclone catch acetone wash); 10 to 2.5 μm (PM₁₀ sizing cyclone exit acetone wash and PM_{2.5} sizing cyclone catch acetone wash); and ≤ 2.5 μm (PM_{2.5} sizing cyclone exit acetone wash and filter). The PM_{2.5} mass was determined by adding the mass of particulates captured on the filter and the ≤ 2.5 μm wash. The PM₁₀ mass was determined by adding the PM_{2.5} mass and the mass of the 10 to 2.5 μm wash. Total particulate was determined by adding the PM₁₀ mass and the mass of the > 10 μm wash.

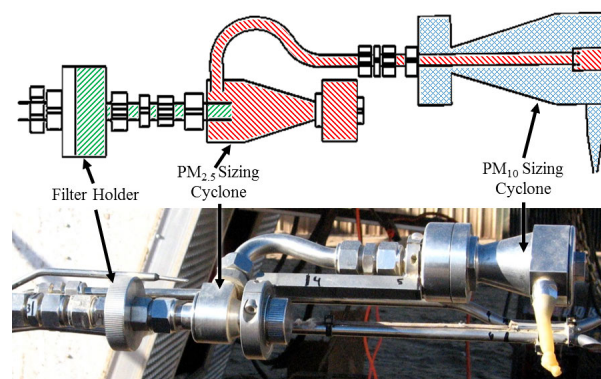

Figure 6. EPA Method 201A PM₁₀ and PM_{2.5} sizing cyclones and in-stack filter holder schematic (CFR, 2010) and photograph (/// ≤ 2.5 μm, /// 10 to 2.5 μm, /// > 10 μm).

Figure 7 shows the performance curves for the PM₁₀ and PM_{2.5} sizing cyclones. To measure both PM₁₀ and PM_{2.5}, Method 201A requires selecting a gas sampling rate in the middle of the overlap zone of the performance curves for both sizing cyclones. For this study, the method was specifically used to collect filterable PM_{2.5} emissions (solid particles emitted by a source at the stack and captured in the ≤ 2.5 μm wash and on the filter [CFR, 2010]). The PM₁₀ sizing cyclone was used to scrub larger particles from the airstream to minimize their impact on the PM_{2.5} sizing cyclone. Thus, the gas sampling rate was targeted to optimize the PM_{2.5} cyclone performance.

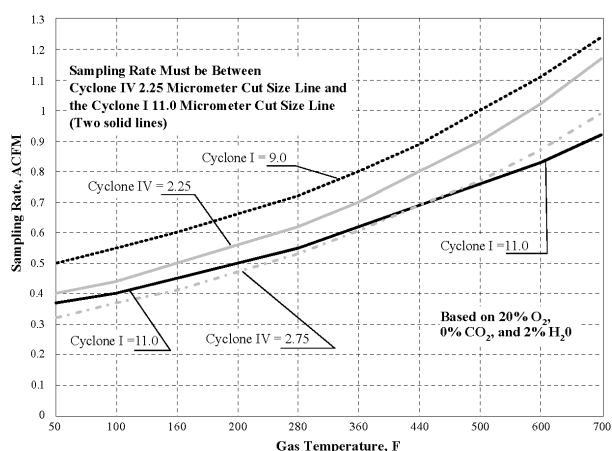

Figure 7. Acceptable sampling rate for combined cyclone heads (CFR, 2010). Cyclone I = PM₁₀ sizing cyclone and Cyclone IV = PM_{2.5} sizing cyclone (gas temperatures for the 2nd stage lint cleaning systems tested ranged from 19 to 42°C [67-107°F]).

Only one stack from each 2nd stage lint cleaning system was tested. For systems with multiple stacks, it was assumed that emissions from each stack of the system were equivalent and the total emissions were calculated by multiplying the measured emissions rates by the total number of cyclones used to control the process tested (EPA, 1996a). To obtain reliable results, the same technician from the same certified stack sampling company (Reliable Emissions Measurements, Auberry, CA), trained and experienced in stack sampling cotton gins, conducted the tests at all seven cotton gins.

All stack sampling equipment, including the sizing cyclones, was purchased from Apex Instruments (Fuquay-Varina, NC) and met specifications of Method 201A. The sampling media were 47-mm Zefluor filters (Pall Corporation, Port Washington, NY) and the sample recovery and analytical reagent was American Chemical Society certified acetone

(A18-4, Fisher Chemical, Pittsburgh, PA; assay ≥ 99.5%). Filters, wash tubs, and lids were pre-labeled and preweighed and stored in sealed containers at the USDA-ARS Air Quality Lab (AQL) in Lubbock, TX, and then transported to each test site. Prior to testing, the certified stack testing technician conducted calibrations and checks on all stack sampling equipment according to EPA Method 201A.

Each cyclone tested was fitted with a cyclone stack extension that incorporated two sampling ports (90° apart) and airflow straightening vanes to eliminate the cyclonic flow of the air exiting the cyclone (Fig. 8). The extensions were designed to meet EPA criteria (EPA, 1989) with an overall length of 3 m (10 ft) and sampling ports 1.2-m (48-in) downstream from the straightening vanes and 0.9-m (36-in) upstream from the extension exit.



Figure 8. Schematic and photographs of stack extensions with sampling ports and straightening vanes (rail attached to extension above sampling port, at right, supports sampling probe during testing traverse).

The tests were conducted by the certified stack sampling technician in an enclosed sampling trailer at the base of the cyclone bank (Fig. 9). Sample retrieval, including filters and sampler head acetone washes, was conducted according to Method 201A. After retrieval, filters were sealed in individual Petri dishes and acetone washes were dried on-site in a conduction oven at 49°C (120°F) and then sealed

with preweighed lids and placed in individual plastic bags for transport to the AQL in Lubbock, TX for gravimetric analyses. During testing, bale data (ID number, weight, and date/time of bale pressing) were either manually recorded by the bale press operator or captured electronically by the gin's computer system for use in calculating emission factors in terms of kg/227-kg bale (lb/500-lb bale). Emission factors and rates were calculated in accordance with Method 201A and ASAE Standard S582 (ASABE, 2005).

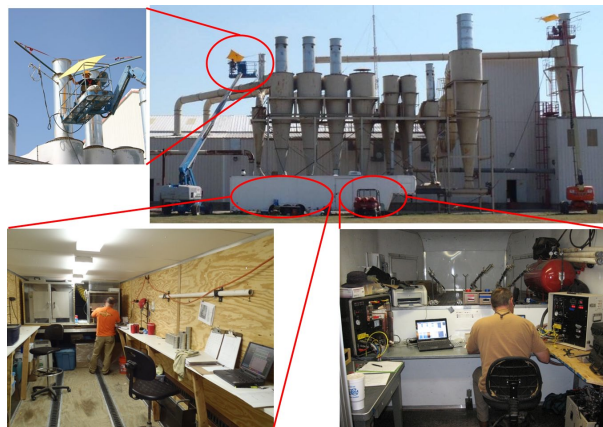

Figure 9. Clockwise from top right: cotton gin stack sampling with air quality lab trailer and technicians on lifts; certified stack sampling technician in the trailer control room conducting tests; sample recovery in trailer clean room; technician operating the probe at stack level.

All laboratory analyses were conducted at the AQL. All filters were conditioned in an environmental chamber ($21 \pm 2^\circ\text{C}$ [$70 \pm 3.6^\circ\text{F}$]; $35 \pm 5\%$ RH) for 48 h prior to gravimetric analyses. Filters were weighed in the environmental chamber on a Mettler MX-5 microbalance (Mettler-Toledo Inc., Columbus, OH; $1 \mu\text{g}$ readability and $0.9 \mu\text{g}$ repeatability) after being passed through an antistatic device. The MX-5 microbalance was leveled on a marble table and housed inside an acrylic box to minimize the effects of air currents and vibrations. To reduce recording errors, weights were digitally transferred from the microbalance directly to a spreadsheet. Technicians wore latex gloves and a particulate respirator mask to avoid contamination. AQL procedures required that each sample be weighed three times. If the standard deviation of the weights for a given sample exceeded $10 \mu\text{g}$, the sample was reweighed. Gravimetric procedures for the acetone wash tubs were the same as those used for filters.

In addition to gravimetric analyses, each sample was visually inspected for unusual characteristics, such as cotton lint content or extraneous material.

Digital pictures were taken of all filters and washes for documentation purposes prior to further analyses. After the laboratory analyses were completed all stack sampling, cotton gin production, and laboratory data were merged.

Four of the seven gins were equipped with 2nd stage lint cleaning systems that were not combined with 1st stage lint cleaning systems. The 2nd stage lint cleaning systems sampled were typical for the industry. Gins A, C, and F had similar systems (Fig. 10). For these systems, the cotton fiber or lint material was pneumatically conveyed from the 1st stage lint cleaning system to the 2nd stage lint cleaner. At the 2nd lint cleaner, the lint was separated from the conveying air by a screened separator and fed into the lint cleaner. The airstream then passed through a fan and exhausted through one or more cyclones. The 2nd stage lint cleaning systems at gin B were similar, except each 2nd stage lint cleaning system processed material/airstreams from two 1st stage lint cleaning systems (Fig. 11).

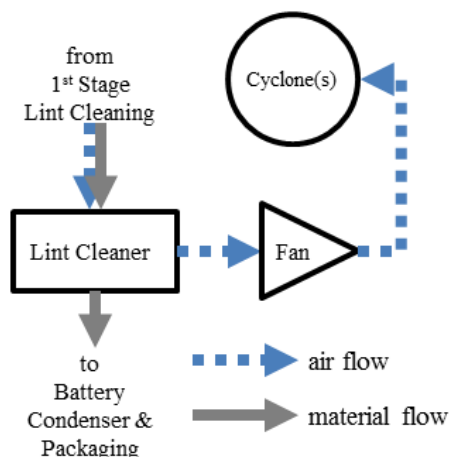

Figure 10. Schematic of 2nd stage lint cleaning system preceded by single 1st stage lint cleaning system (gins A, C, and F).

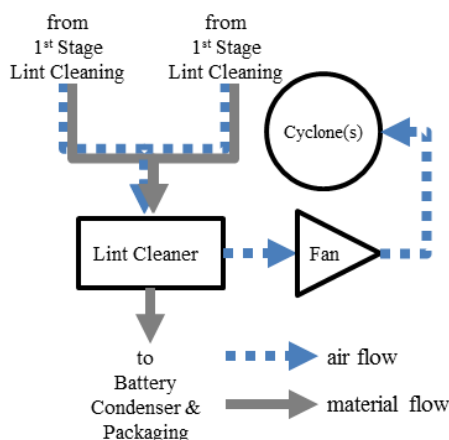

Figure 11. Schematic of 2nd stage lint cleaning system preceded by double 1st stage lint cleaning systems (gin B).

Table 1. Abatement device configuration^z for 2nd stage lint cleaning systems tested.

Gin	Cyclone Type	Inlet Design	Systems per Gin	Cyclones per Gin	Configuration	Cone Design	Trash Exits to ^y
A	1D3D	2D2D	3	6	dual	expansion chamber	auger
B	1D3D	2D2D	2	4	dual	expansion chamber	robber
C	1D3D	2D2D	2	4	dual	standard	robber
F	1D3D	2D2D	4	4	single	standard	robber

^z Figures 5 and 12^y Systems to remove material from cyclone trash exits: auger = enclosed, screw-type conveyor, robber = pneumatic suction system

All 2nd stage lint cleaning systems sampled utilized 1D3D cyclones to control emissions (Fig. 5), but there were some cyclone design variations among the gins (Table 1 and Fig. 12). All the gins, except gin F, split the system exhaust flow between two cyclones in a dual configuration (side by side as opposed to one behind another). The system airstream for gin F was exhausted through a single cyclone. Inlets on all the 2nd stage lint cleaning cyclones were 2D2D type. Expansion chambers were present on 2nd stage lint cleaning system cyclones at gins A and B. Gins C and F had standard cones. The cyclones tested at gins B, C, and F had cyclone robber systems pulling airflow from their trash exits. This configuration helps remove lint and trash from the cyclone that could otherwise circulate near the trash exit at the bottom of the cone for a period of time before dropping out. All of the cyclone variations outlined above, if properly designed and maintained, are recommended for controlling cotton gin emissions (Whitelock et al., 2009).



Figure 12. Cyclone design variations for the tested systems (left to right): dual configuration that splits flow between identical 1D3D cyclones with 2D2D inlets; 1D3D cyclone with 2D2D inlet and expansion chamber on the cone; 1D3D cyclone with 2D2D inlet and standard cone.

RESULTS

Table 2 shows the test parameters for each Method 201A test run for the 2nd stage lint cleaning systems sampled at the four gins. The system average ginning rate was 27.3 bales/h and the test average ginning rates at each gin ranged from 15.1 to 46.4 bales/h (based on 227-kg [500-lb] equivalent bales). The capacity of gins sampled was representative of the industry average, approximately 25 bales/h. The 1D3D cyclones were all operated with inlet velocities within design criteria, 16.3 ± 2 m/s (3200 ± 400 fpm), except all the test runs at gin A and the first and third test runs at gin C, which were outside the design range due to limitations in available system adjustments.

There are criteria specified in EPA Method 201A for test runs to be valid for PM_{2.5}, PM₁₀, or total particulate measurements (CFR, 2010). Isokinetic sampling must fall within EPA defined ranges ($100 \pm 20\%$) for valid PM_{2.5} and PM₁₀ test runs. All tests met the isokinetic criteria (Table 2), except the third test run at gin C; this run was omitted from the PM_{2.5} and PM₁₀ test averages. The PM_{2.5} aerodynamic cut size must fall within EPA defined ranges (2.50 ± 0.25 mm) for valid PM_{2.5} test runs. PM_{2.5} cut size criteria were not met in the third test run for either gin A or C or the first test run for gin B, thus the data associated with these runs were omitted from the PM_{2.5} test averages. The PM₁₀ aerodynamic cut size must fall within EPA defined ranges (10.0 ± 1.0 mm) for valid PM₁₀ test runs. PM₁₀ cut size criteria were not met in the second test run for gin C or the first test run for gin F, thus the data associated with these runs were omitted from the PM₁₀ test averages. To use the method to obtain total filterable particulate also, sampling must be within 90 to 110% of isokinetic flow. This criterion was not met in all the test runs for gin C; thus the data associated with these runs were omitted from the total particulate test averages.

Table 2. Cotton gin production data and stack sampling performance metrics for the 2nd stage lint cleaning systems.

Gin	Test Run	Ginning Rate, bales/h ^z	Cyclone Inlet Velocity		Isokinetic Sampling, %	Aerodynamic Cut Size D ₅₀		Sampling Rate ^y		Stack Temperature	
			m/s	fpm		PM _{2.5} μm	PM ₁₀ μm	slpm	scfm	°C	°F
A	1	23.3	18.9	3715	97	2.42	10.9	11.5	0.406	19	67
	2	22.9	18.9	3721	99	2.39	10.8	11.8	0.416	22	72
	3	19.5	18.6	3658	110	2.15 ^v	10.1	12.9	0.454	23	74
	Test Average	21.9	18.8	3698							
B	1	24.6	15.6	3078	107	2.23 ^v	10.5	12.4	0.436	39	103
	2	25.5	15.7	3091	103	2.35	10.8	11.9	0.420	40	104
	3	26.7	15.5	3055	108	2.26	10.6	12.3	0.436	42	107
	Test Average	25.6	15.6	3074							
C	1	18.0	13.7	2704	113 ^w	2.38	10.9	11.4	0.403	31	88
	2	15.4	14.5	2863	86 ^w	2.45	11.1 ^v	11.1	0.393	31	88
	3	11.9	14.1	2773	121 ^{wx}	2.13 ^v	10.2	12.5	0.443	31	87
	Test Average	15.1	14.1	2780							
F	1	51.3	15.2	2989	96	2.48	11.1 ^v	11.3	0.398	28	83
	2	44.5	15.3	3019	97	2.43	10.9	11.5	0.408	30	86
	3	43.5	14.9	2942	107	2.40	10.9	11.7	0.414	32	89
	Test Average	46.4	15.2	2983							
System Average	27.3	15.9	3134								

^z 227 kg (500 lb) equivalent bales^y slpm = standard l/m, scfm = standard ft³/min^x Did not meet PM_{2.5} or PM₁₀ isokinetic sampling rate criteria (100 ± 20%)^w Did not meet total particulate isokinetic sampling rate criteria (100 ± 10%)^v Did not meet PM_{2.5} (2.50 ± 0.25 μm) or PM₁₀ (10.0 ± 1.0 μm) aerodynamic cut size criteria

Sampling rates ranged from 11.1 to 12.9 standard l/min (0.393 to 0.454 standard ft³/min) (Table 2). The stack gas temperatures ranged from 19 to 42°C (67-107°F). The sampling method documentation (CFR, 2010) warns that the acceptable gas sampling rate range is limited at the stack gas temperatures encountered during this project's testing, as indicated by the narrow difference between the solid lines in Fig. 7 for the temperatures listed above. These stack gas characteristics justified targeting the PM_{2.5} cut size criteria and treating the PM₁₀ cut size criteria as secondary.

PM_{2.5} emissions data (ginning and emission rates and corresponding emission factors) for the 2nd stage lint cleaning systems are shown in Table 3. The system average PM_{2.5} emission factor was 0.0051 kg/bale (0.011 lb/bale). The test average emission factors at each gin ranged from 0.0028 to 0.0080 kg (0.0061-0.018 lb) per bale and PM_{2.5} emission rates ranged from 0.067 to 0.38 kg/h (0.15-0.83

lb/h). PM₁₀ emissions data (ginning and emission rates and corresponding emission factors) for the 2nd stage lint cleaning systems are shown in Table 4. The system average PM₁₀ emission factor was 0.022 kg/bale (0.048 lb/bale). The test average emission factors ranged from 0.010 to 0.028 kg (0.022-0.062 lb) per bale and emission rates ranged from 0.26 to 1.23 kg/h (0.57-2.72 lb/h). Total particulate emissions data (ginning and emission rates and corresponding emission factors) for the 2nd stage lint cleaning systems are shown in Table 5. The system average total particulate emission factor was 0.033 kg/bale (0.074 lb/bale). The test average emission factors ranged from 0.014 to 0.047 kg (0.032-0.105 lb) per bale. Test average total particulate emission rates ranged from 0.37 to 2.21 kg/h (0.81-4.87 lb/h). The ratios of PM_{2.5} to total particulate, PM_{2.5} to PM₁₀, and PM₁₀ to total particulate were 15.2, 23.1, and 65.7%, respectively (ratios calculated using Tables 3, 4, and 5 might vary slightly from those listed due to rounding).

Table 3. PM_{2.5} emissions data for the 2nd stage lint cleaning systems.

Gin	Test Run	Emission Rate		Emission Factor	
		kg/h	lb/h	kg/bale ^z	lb/bale ^z
A	1	0.051	0.11	0.0022	0.0048
	2	0.083	0.18	0.0036	0.0080
	3 ^y	0.084	0.19	0.0043	0.010
Test Average (n=2)		0.067	0.15	0.0029	0.0064
B	1 ^y	0.071	0.16	0.0029	0.0063
	2	0.083	0.18	0.0033	0.0072
	3	0.060	0.13	0.0022	0.0050
Test Average (n=2)		0.072	0.16	0.0028	0.0061
C	1	0.12	0.27	0.0068	0.015
	2	0.10	0.22	0.0064	0.014
	3 ^y	0.022	0.049	0.0019	0.0041
Test Average (n=2)		0.11	0.24	0.0066	0.015
F	1	0.45	0.99	0.0088	0.019
	2	0.36	0.79	0.0080	0.018
	3	0.32	0.70	0.0073	0.016
Test Average (n=3)		0.38	0.83	0.0080	0.018
System Average (n=4)				0.0051	0.011

^z 227 kg (500 lb) equivalent bales

^y Test run omitted from test averages because isokinetic sampling rate (100 ± 20%) and/or aerodynamic cut size (2.50 ± 0.25 µm) were not met.

Table 4. PM₁₀ emissions data for the 2nd stage lint cleaning systems.

Gin	Test Run	Emission Rate		Emission Factor	
		kg/h	lb/h	kg/bale ^z	lb/bale ^z
A	1	0.49	1.08	0.021	0.046
	2	0.64	1.41	0.028	0.061
	3	0.52	1.15	0.027	0.059
Test Average (n=3)		0.55	1.21	0.025	0.056
B	1	0.30	0.66	0.012	0.027
	2	0.28	0.62	0.011	0.024
	3	0.19	0.43	0.0073	0.016
Test Average (n=3)		0.26	0.57	0.010	0.022
C	1	0.44	0.97	0.025	0.054
	2 ^y	0.33	0.72	0.021	0.047
	3 ^y	0.28	0.61	0.023	0.051
Test Average (n=1)		0.44	0.97	0.025	0.054
F	1 ^y	1.67	3.67	0.033	0.072
	2	1.51	3.34	0.034	0.075
	3	0.95	2.10	0.022	0.048
Test Average (n=2)		1.23	2.72	0.028	0.062
System Average (n=4)				0.022	0.048

^z 227 kg (500 lb) equivalent bales

^y Test run omitted from test averages because isokinetic sampling rate (100 ± 20%) and/or aerodynamic cut size (10.0 ± 1.0 µm) were not met.

Table 5. Total particulate emissions data for the 2nd stage lint cleaning systems.

Gin	Test Run	Emission Rate		Emission Factor	
		kg/h	lb/h	kg/bale ^z	lb/bale ^z
A	1	0.78	1.72	0.033	0.074
	2	0.92	2.03	0.040	0.089
	3	0.82	1.80	0.042	0.092
Test Average (n=3)		0.84	1.85	0.038	0.085
B	1	0.40	0.88	0.016	0.036
	2	0.39	0.85	0.015	0.033
	3	0.31	0.69	0.012	0.026
Test Average (n=3)		0.37	0.81	0.014	0.032
C	1 ^y	0.54	1.20	0.030	0.067
	2 ^y	0.41	0.90	0.026	0.058
	3 ^y	0.35	0.78	0.030	0.065
Test Average (n=0)					
F	1	2.44	5.38	0.048	0.105
	2	2.45	5.39	0.055	0.121
	3	1.79	3.83	0.040	0.088
Test Average (n=3)		2.21	4.87	0.047	0.105
System Average (n=3)				0.033	0.074

^z 227 kg (500 lb) equivalent bales

^y Test run omitted from test averages because isokinetic sampling rate (100 ± 10%) was not met.

The 2nd stage lint cleaning system total particulate emission factor average for this project was about 12.7% of the EPA AP-42 published value for the lint cleaners with high-efficiency cyclones (EPA, 1996a, b), which is an equivalent system to combined 1st and 2nd stage lint cleaning systems. The range of test average total particulate emission factors determined for this project and the range of AP-42 emission factor data overlapped. The 2nd stage lint cleaning system PM₁₀ emission factor average for this project was 20.2% of the EPA AP-42 published value for the lint cleaners with high-efficiency cyclones. The test average PM₁₀ emission factor range also overlapped with the AP-42 emission factor data range.

Figure 13 shows an example of samples recovered from a typical 2nd stage lint cleaning system test run. Often, there were cotton lint fibers, which have cross-sectional diameters much greater than 2.5 µm, in the cotton gin cyclone exhausts. Therefore, it was not unusual to find lint fiber in the > 10 µm wash from Method 201A. However, in the atypical sample shown in Fig. 14, lint fibers passed through the PM₁₀ cyclone and collected in the 10 to 2.5 µm and on the filter. This type of material carryover

can bias the gravimetric measurements and impact reported emissions data. EPA Method 201A does not suggest methods to account for these anomalies. Thus, no effort was made to adjust the data reported in this manuscript to account for these issues.

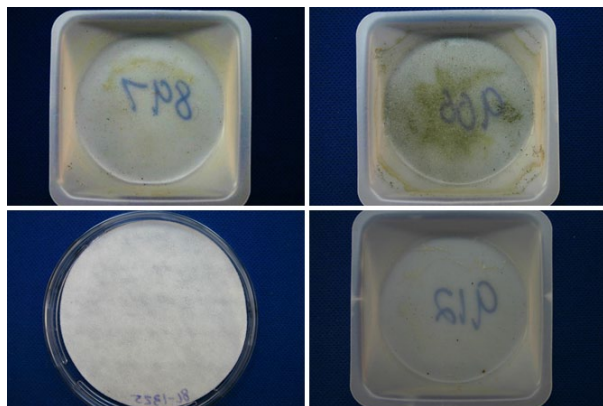

Figure 13. Typical EPA Method 201A filter and sampler head acetone washes from the 2nd stage lint cleaning system. Clockwise from top left: > 10 μm wash, 10 to 2.5 μm wash, \leq 2.5 μm wash and filter.



Figure 14. Atypical EPA Method 201A filter and sampler head acetone wash from the 2nd stage lint cleaning system with lint fiber in the 10 to 2.5 μm wash and on the filter. Left to right: 10 to 2.5 μm wash and filter.

SUMMARY

Seven cotton gins across the U.S. cotton belt were stack sampled using EPA Method 201A to fill the data gap that exists for PM_{2.5} cotton gin emissions data. Four of the seven gins had 2nd stage lint cleaning systems where the system exhaust was equipped with cyclones and exhaust airstream was not combined with a 1st stage lint cleaning system. The tested systems were similar in design and typical of the ginning industry. All the systems were equipped with 1D3D cyclones for emissions control with some slight variations in inlet and cone design. In terms of capacity, the four gins were typical of the industry, averaging 27.3 bales/h during testing. Some test runs were excluded from the test averages because they failed to meet EPA Method 201A test criteria. Also, other test runs included in the analyses had cotton lint fibers that collected in the \leq 10 μm

and/or \leq 2.5 μm samples. This larger lint material can impact the reported emissions data, but EPA Method 201A does not suggest methods to account for these anomalies. Average measured 2nd stage lint cleaning system PM_{2.5} emission factor based on the four gins tested (nine total test runs) was 0.0051 kg/227-kg bale (0.011 lb/500-lb bale). The 2nd stage lint cleaning system emission factors for PM₁₀ and total particulate were 0.022 kg/bale (0.048 lb/bale) and 0.033 kg/bale (0.074 lb/bale), respectively. The gin test average PM_{2.5}, PM₁₀, and total particulate emission rates ranged from 0.067 to 0.38 kg/h (0.15-0.83 lb/h), 0.26 to 1.23 kg/h (0.57-2.72 lb/h), and 0.37 to 2.21 kg/h (0.81-4.87 lb/h), respectively. System average PM₁₀ and total particulate emission factors were lower than those currently published in EPA AP-42. The ratios of 2nd stage lint cleaning system PM_{2.5} to total particulate, PM_{2.5} to PM₁₀, and PM₁₀ to total particulate were 15.2, 23.1, and 65.7%, respectively. These data are the first published data to document PM_{2.5} emissions from 2nd stage lint cleaning systems at cotton gins.

ACKNOWLEDGMENTS

The authors appreciate the cooperating gin managers and personnel who generously allowed and endured sampling at their gins. In addition, we thank California Cotton Ginners' and Growers' Association, Cotton Incorporated, San Joaquin Valleywide Air Pollution Study Agency, Southeastern Cotton Ginners' Association, Southern Cotton Ginners' Association, Texas Cotton Ginners' Association, Texas State Support Committee, and The Cotton Foundation for funding this project. The authors also thank the Cotton Gin Advisory Group and Air Quality Advisory Group for their involvement and participation in planning, execution, and data analyses for this project that is essential to developing quality data that will be used by industry, regulatory agencies, and the scientific community. The advisory groups included: the funding agencies listed above, California Air Resources Board, Missouri Department of Natural Resources, National Cotton Council, National Cotton Ginners' Association, North Carolina Department of Environment and Natural Resources, San Joaquin Valley Air Pollution Control District, Texas A&M University, Texas Commission on Environmental Quality, USDA-NRCS National Air Quality and Atmospheric Change, and U.S. Environmental Protection Agency (national, Region 4 and 9).

DISCLAIMER

Mention of trade names or commercial products in this publication is solely for the purpose of providing specific information and does not imply recommendation or endorsement by the Oklahoma State University or U.S. Department of Agriculture. Oklahoma State University and USDA are equal opportunity providers and employers.

REFERENCES

- American Society of Agricultural and Biological Engineers (ASABE). 2005. Cotton Gins—Method of Utilizing Emission Factors in Determining Emission Parameters. ASAE S582, March 2005. American Society of Agricultural and Biological Engineers, St. Joseph, MI.
- Buser, M.D., D.P. Whitlock, J.C. Boykin, and G.A. Holt. 2012. Characterization of cotton gin particulate matter emissions—Project plan. *J. Cotton Sci.* 16:105–116.
- Code of Federal Regulations (CFR). 2006. National ambient air quality standards for particulate matter; final rule. 40 CFR, Part 50. U.S. Government Printing Office, Washington, D.C.
- Code of Federal Regulations (CFR). 2010. Method 201A—Determination of PM₁₀ and PM_{2.5} emissions from stationary sources (Constant sampling rate procedure). 40 CFR 51, Appendix M. Available at <http://www.epa.gov/ttn/emc/promgate/m-201a.pdf> (verified 19 Aug. 2013).
- Environmental Protection Agency (EPA). 1989. Particulate sampling in cyclonic flow. U.S. Environmental Protection Agency, Washington, DC. Available online at <http://www.epa.gov/ttn/emc/guidlnd/gd-008.pdf> (verified 19 Aug. 2013).
- Environmental Protection Agency (EPA). 1996a. Emission factor documentation for AP-42, Section 9.7, Cotton Ginning (EPA Contract No. 68-D2-0159; MRI Project No. 4603-01, Apr. 1996). Publ. AP-42. U.S. Environmental Protection Agency, Washington, DC.
- Environmental Protection Agency (EPA). 1996b. Food and agricultural industries: Cotton gins. *In* Compilation of air pollution emission factors, Volume 1: Stationary point and area sources. Publ. AP-42. U.S. Environmental Protection Agency, Washington, DC.
- Environmental Protection Agency (EPA). 2010. Frequently asked questions (FAQS) for Method 201A [Online]. Available at <http://www.epa.gov/ttn/emc/methods/method201a.html> (verified 19 Aug. 2013).
- National Agricultural Statistics Service (NASS). 1993–2012. Cotton Ginnings Annual Summary [Online]. USDA National Agricultural Statistics Service, Washington, DC Available at <http://usda.mannlib.cornell.edu/MannUsda/viewDocumentInfo.do?documentID=1042> (verified 19 Aug. 2013).
- Valco, T.D., H. Ashley, J.K. Green, D.S. Findley, T.L. Price, J.M. Fannin, and R.A. Isom. 2012. The cost of ginning cotton—2010 survey results. p. 616–619 *In* Proc. Beltwide Cotton Conf., Orlando, FL. 3–6 Jan. 2012. Natl. Cotton Counc. Am., Memphis, TN.
- Valco, T.D., B. Collins, D.S. Findley, J.K. Green, L. Todd, R.A. Isom, and M.H. Wilcutt. 2003. The cost of ginning cotton—2001 survey results. p. 662–670 *In* Proc. Beltwide Cotton Conf., Nashville, TN. 6–10 Jan. 2003. Natl. Cotton Counc. Am., Memphis, TN.
- Valco, T.D., J.K. Green, R.A. Isom, D.S. Findley, T.L. Price, and H. Ashley. 2009. The cost of ginning cotton—2007 survey results. p. 540–545 *In* Proc. Beltwide Cotton Conf., San Antonio, TX. 5–8 Jan. 2009. Natl. Cotton Counc. Am., Memphis, TN.
- Valco, T.D., J.K. Green, T.L. Price, R.A. Isom, and D.S. Findley. 2006. Cost of ginning cotton—2004 survey results. p. 618–626 *In* Proc. Beltwide Cotton Conf., San Antonio, TX. 3–6 Jan. 2006. Natl. Cotton Counc. Am., Memphis, TN.
- Wakelyn, P.J., D.W. Thompson, B.M. Norman, C.B. Nevius, and D.S. Findley. 2005. Why cotton ginning is considered agriculture. *Cotton Gin and Oil Mill Press* 106(8):5–9.
- Whitlock, D.P., C.B. Armijo, M.D. Buser, and S.E. Hughs. 2009. Using cyclones effectively at cotton gins. *Appl. Eng. Ag.* 25:563–576.